

LINE	BEARING	DISTANCE
L1	N 10°45'20" E	2.32'
L2	N 11°36'43" E	160.30'
L3	N 12°06'03" E	50.38'
L4	N 11°56'53" E	50.19'
L5	N 11°31'40" E	50.14'
L6	N 11°38'39" E	201.24'
L7	N 11°41'54" E	100.75'
L8	S 75°57'01" E	25.28'
L9	S 76°40'03" E	55.90'
L10	S 72°38'43" E	22.36'
L11	S 46°28'18" E	15.02'
L12	S 65°18'15" E	45.58'
L13	S 60°11'34" E	27.72'
L14	S 33°18'48" E	23.79'
L15	S 45°48'39" E	41.69'
L16	S 39°49'54" E	66.35'
L17	S 33°53'21" E	15.75'
L18	N 01°38'47" W	272.58'
L19	N 78°21'49" W	244.62'
L20	N 11°40'49" E	378.60'
L21	S 89°38'50" E	89.65'
L22	S 83°43'20" W	69.41'
L23	N 83°14'58" W	37.13'
L24	S 05°32'13" E	351.52'
L25	S 68°59'00" W	346.92'
L26	N 83°14'07" W	677.78'
L27	N 11°36'43" E	159.95'
L28	N 12°06'03" E	50.29'
L29	N 11°56'53" E	50.34'
L30	N 11°31'40" E	50.22'
L31	N 11°38'39" E	201.19'
L32	N 11°41'54" E	100.58'
L33	N 11°24'57" E	142.89'
L34	N 11°40'49" E	142.20'
L35	S 82°16'59" E	44.17'
L36	N 11°40'49" E	44.17'
L37	N 82°16'59" W	44.17'
L38	N 11°40'49" E	198.22'
L39	S 06°41'09" E	166.56'
L40	S 57°06'37" E	178.40'
L41	S 39°12'21" W	89.86'
L42	N 50°38'01" W	187.06'
L43	S 39°10'21" W	200.02'
L44	S 50°37'56" E	186.94'
L45	S 39°12'21" W	183.89'
L46	S 89°24'37" W	245.29'
L47	S 78°39'37" E	62.00'
L48	S 60°49'14" E	71.48'
L49	N 86°02'01" E	4.74'
L50	N 11°40'49" E	44.17'
L51	N 05°32'13" W	288.61'
L52	S 50°38'01" E	0.23'
L53	S 50°37'56" E	0.25'
L54	N 23°18'50" E	121.79'
L55	S 76°40'03" E	4.74'
L56	S 39°12'21" W	200.03'

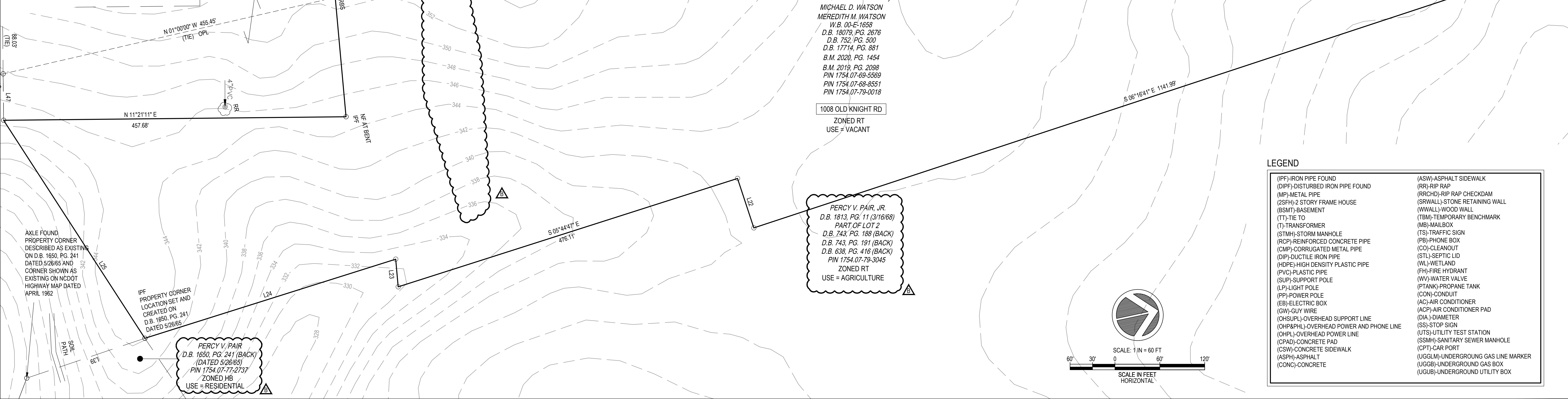

REVISIONS	DATE	DESCRIPTION
A	02/22/2021	TOWN OF KNIGHTDALE COMMENTS
B	05/07/2021	TOWN OF KNIGHTDALE COMMENTS

STATUS: FOR REVIEW ONLY
NOT FOR CONSTRUCTION

DATE: DECEMBER 17, 2020 HORZ. SCALE: 1" = 60'
FILE NO. 2018-022 ORIG. SHEET SIZE: 24 x 36

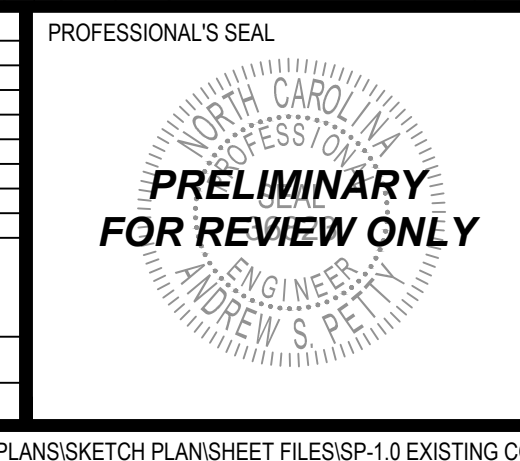

Curry
ENGINEERING

EST. 1987
N.C. LIC. NO. P-0799

T: (919) 552-0840
F: (919) 552-2043

205 S. Fugate Avenue
Fayetteville, NC 27325

ENVISION HOMES
a better life

Envision Homes
4441 Six Forks Road, Suite 106-117
Raleigh, NC 27609
919.389.7595 (m)
Contact: Josh Swindell
josh@envisionhomesnc.com

SKETCH PLAN REVIEW
FORESTVILLE YARD
EXISTING CONDITIONS PLAN

SP-1.0

SITE DATA TABLE	
SITE AREA	26.54 ac
ZONING	RT
LAND USE	Residential
REZONING REQUIRED (Y/N)	Y
REZONING DISTRICT	PUD
MAXIMUM DENSITY	18 units/ac
MAXIMUM NUMBER OF UNITS	477 units
PROPOSED UNITS	146 units
26' SF REAR LOAD UNITS	57 (39%)
35' SF REAR LOAD UNITS	41 (28%)
24' TH REAR LOAD UNITS	38 (26%)
18' TH ECONOMY UNITS	10 (7%)
PROPOSED DENSITY	5.50 units/ac
OPEN SPACE REQUIRED	3.06 ac
OPEN SPACE PROVIDED	3.06 ac
TREE COVERAGE REQUIRED	2.65 ac
TREE COVERAGE PROVIDED	2.72 ac
STORMWATER MANAGEMENT AREA	1.28 ac
CONNECTIVITY (LINK TO NODE RATIO)	1.75

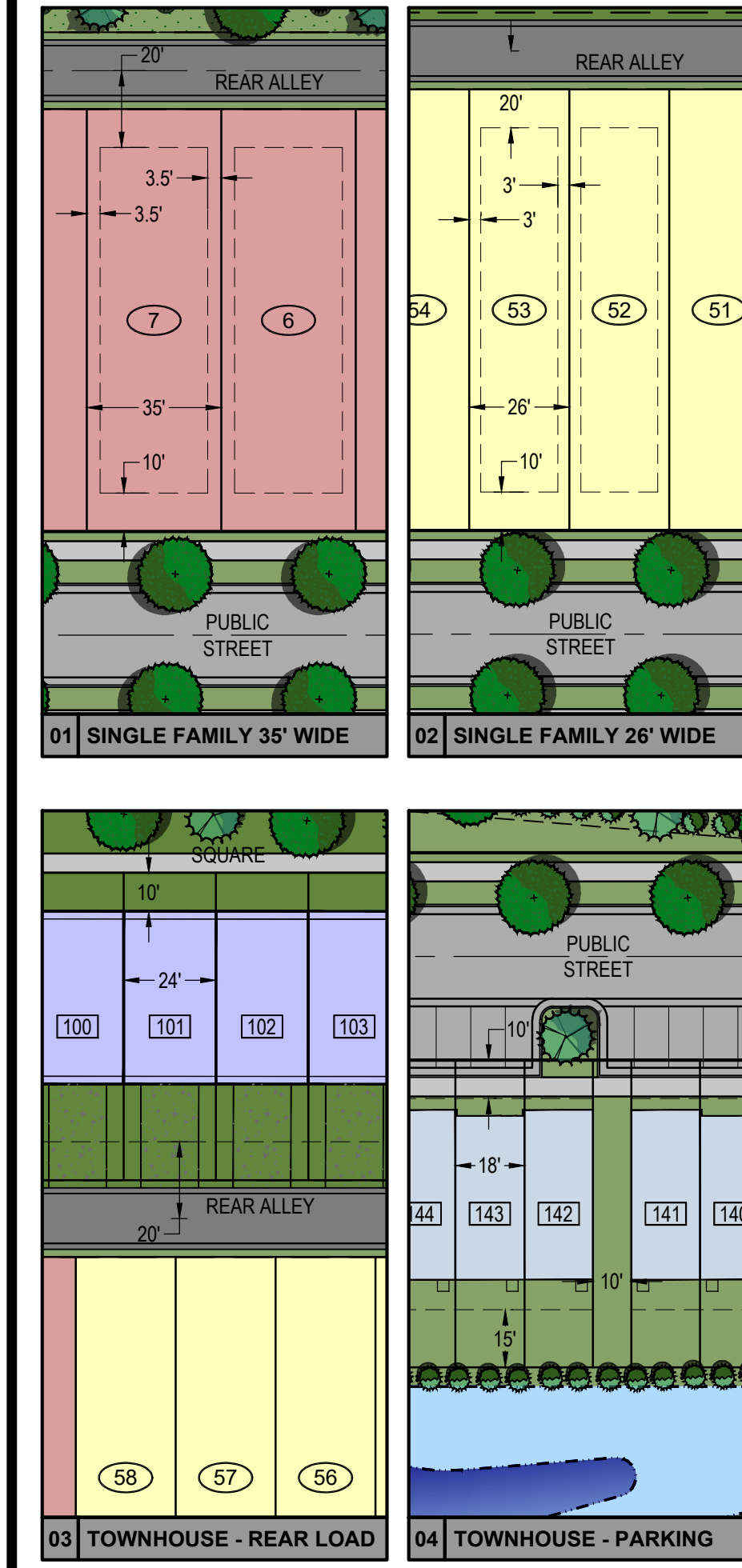

LEGEND			
	26' WIDE SINGLE FAMILY LOTS		ACTIVE OPEN SPACE
	35' WIDE SINGLE FAMILY LOTS		PASSIVE OPEN SPACE
	24' WIDE TOWNHOMES		STORMWATER AREA
	ECONOMY TOWNHOMES		TREE PRESERVATION AREA
	POOL		



TREE COVERAGE CALCULATION	
TREE COVERAGE AREA CALCULATION	
Perimeter of Tract =	6395 ft
Buffer Width =	20 ft
Minimum Tree Coverage Area (by calculation) =	127,900 sq ft
Minimum Tree Coverage Area (by calculation) =	2.94 ac
Net Acreage of Tract =	26.54 ac
Minimum Tree Coverage Area (10%) =	2.65 ac
Percentage of Tract =	11%
Minimum Area Required =	2.65 ac
Area of Stream and Perimeter Buffers =	1.43 ac
Additional Tree Coverage Area Needed =	1.22 ac
Area of Additional Tree Coverage Areas =	1.29 ac
Total Tree Coverage Area =	2.72 ac

OPEN SPACE CALCULATION	
Development Information	
Net Acreage of Tract =	26.54 ac
Number of Units =	146 du
Density =	5.50 du/ac
Number of 3-bedroom Units =	105 du
Number of 4-bedroom Units =	41 du
Acreage of Tract with 1/4 mile =	23.36 du
Acreage of Tract between 1/4-1/2 mile =	3.18 du
Acreage of Tract outside 1/2 mile =	0 du
Total Number of Bedrooms =	479 bedrooms
From Chart above	
Gross Density Range =	2-6
Rate of Open Space at 1/4 mile =	260
Rate of Open Space 1/4-1/2 mile =	390
Rate of Open Space over 1/2 mile =	520
Calculated Values	
Bedrooms at 1/4 mile =	422
Bedrooms at 1/4-1/2 mile =	58
Bedrooms over 1/2 mile =	0
Open Space Required =	132,340 sf
Open Space Provided =	3.04 ac
Percentage of Site	
Active Open Space Required =	1.52 ac
Active Open Space Provided =	2.47 ac
Passive Open Space Required =	0.57 ac
Passive Open Space Provided =	0.59 ac
Total Open Space Provided =	3.06 ac

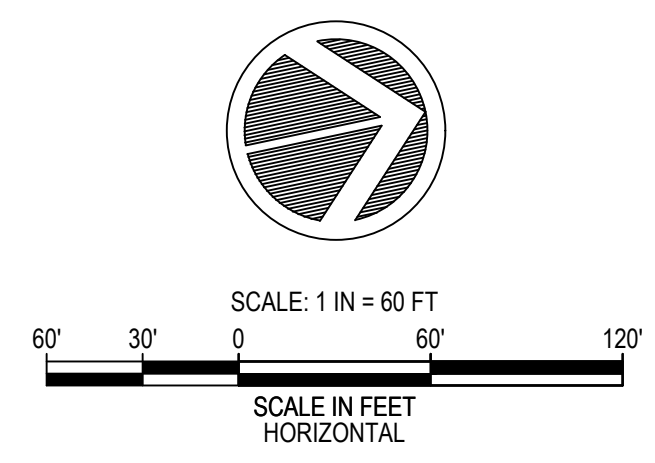

REVISIONS	
A	02/22/2021 TOWN OF KNIGHTDALE COMMENTS

STATUS: FOR REVIEW ONLY, NOT FOR CONSTRUCTION

DATE: DECEMBER 17, 2020 HORZ. SCALE: 1" = 60'

FILE NO. 2018-022 ORIG. SHEET SIZE: 24 x 36

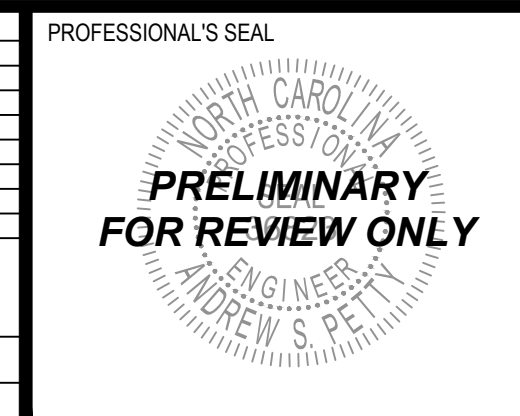

CONSULTANT

Curry
ENGINEERING

EST. 1911
10 NORTH CAROLINA
205 S. FAYETTE AVENUE
FAYETTEVILLE, NC 27325
P: (919) 552-0840
F: (919) 552-2043

NC LIC. NO. P-0799

CLIENT

ENVISION HOMES
a better life

Envision Homes
4441 Six Forks Road, Suite 106-117
Raleigh, NC 27609
919.389.7595 (m)
Contact: Josh Swindell
josh@envisionhomesnc.com

SKETCH PLAN REVIEW
FORESTVILLE YARD
OVERALL SITE PLAN

SP-2.0

Z:\PROJECTS\FOLDER-ZEBULON\2018\2018-022 WATSON TRACT - KNIGHTDALE\PLANS\SKETCH PLAN\SHEET FILES\SP-2.0 OVERALL SITE PLAN.DWG
PLOTTED: 5/7/2021 5:11 PM

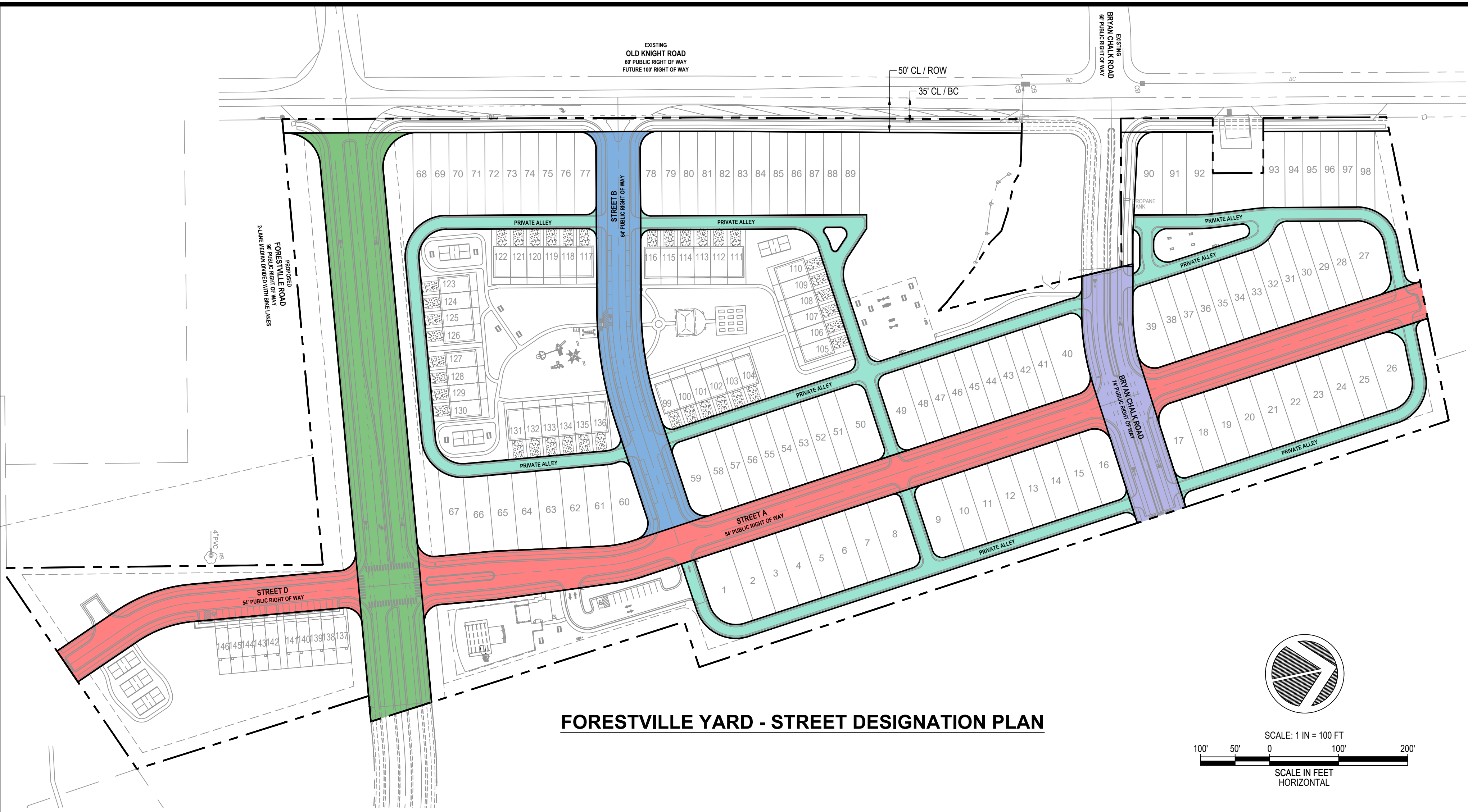

FORESTVILLE YARD - STREET DESIGNATION PLAN

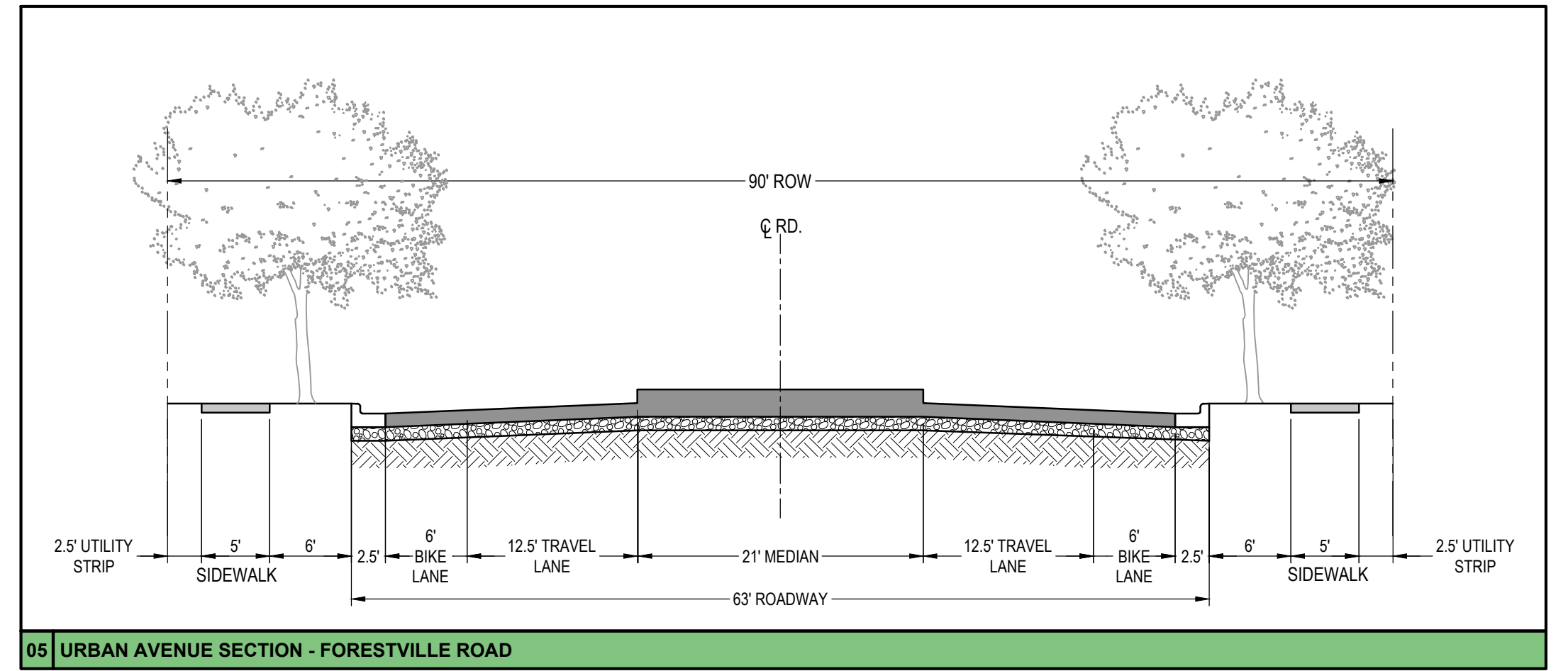
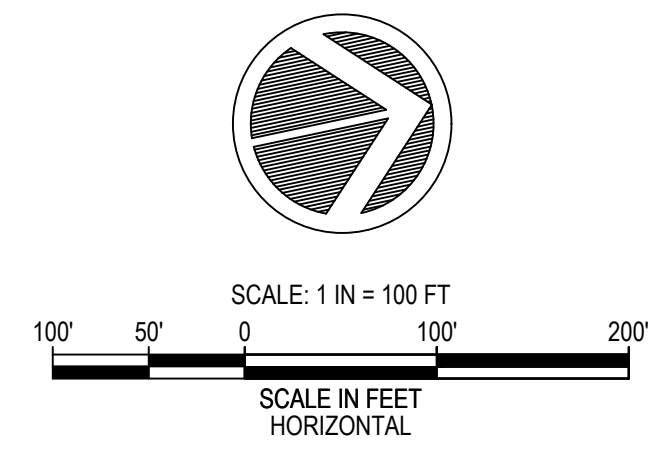

05 URBAN AVENUE SECTION - FORESTVILLE ROAD

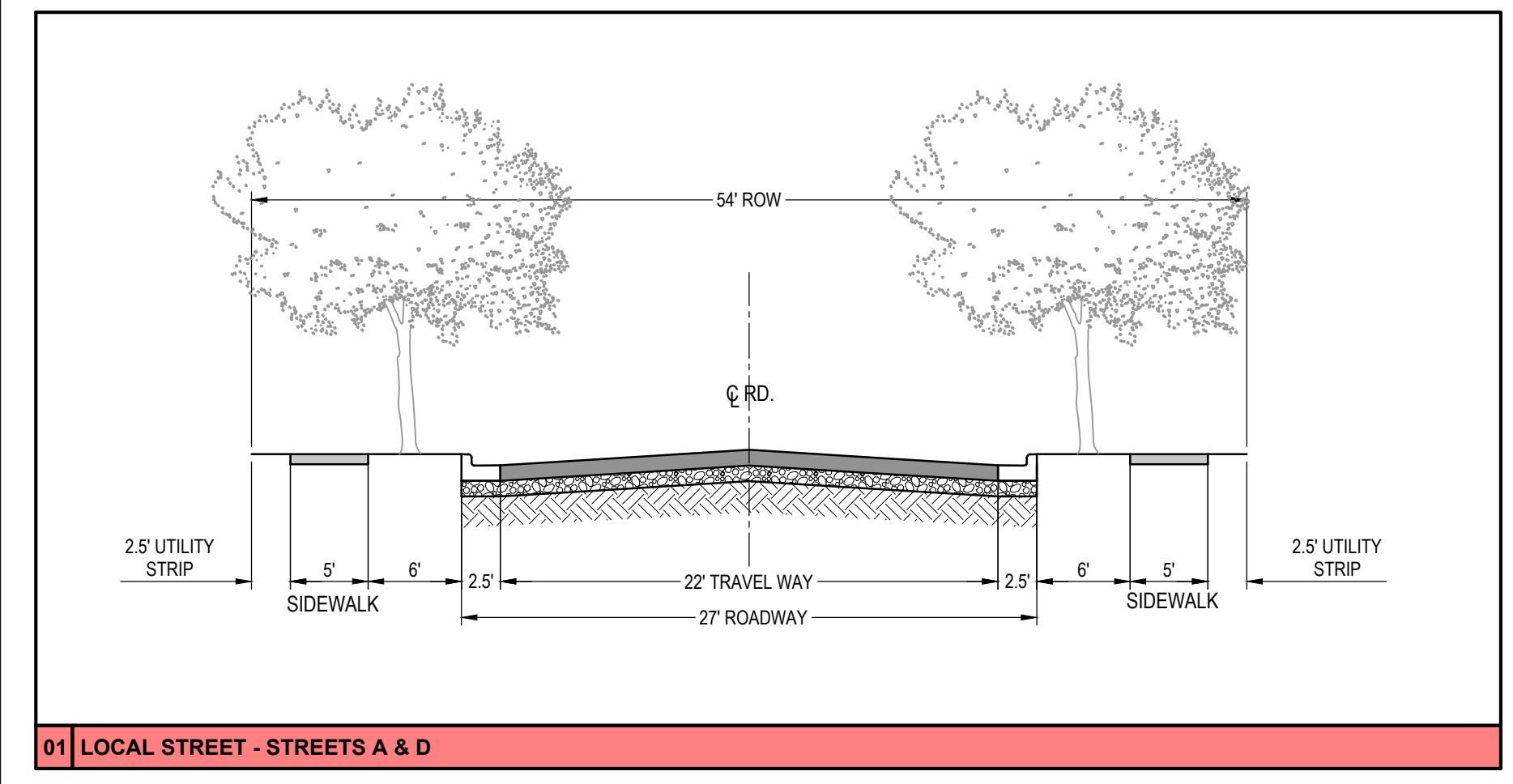

01 LOCAL STREET - STREETS A & D

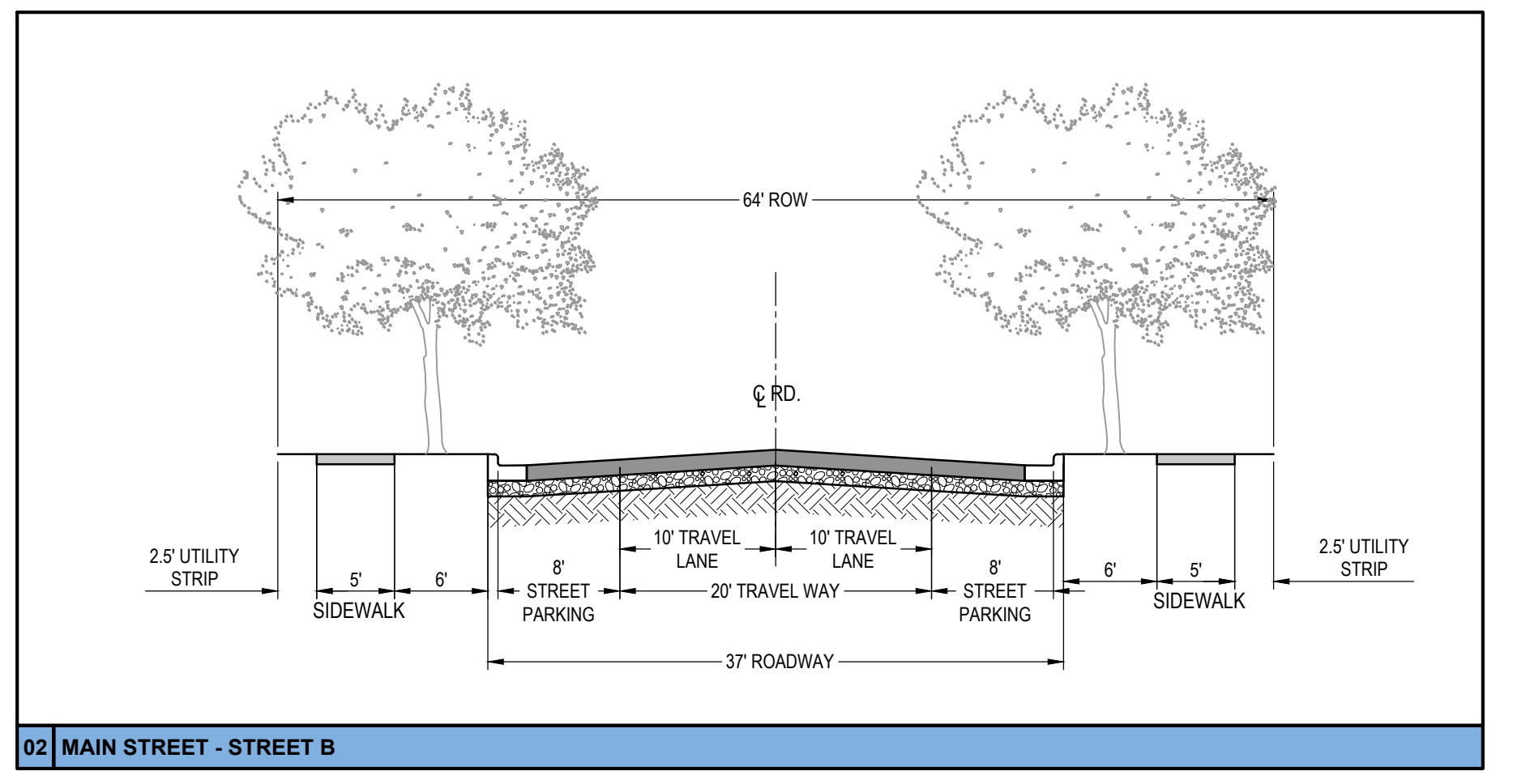

02 MAIN STREET - STREET B

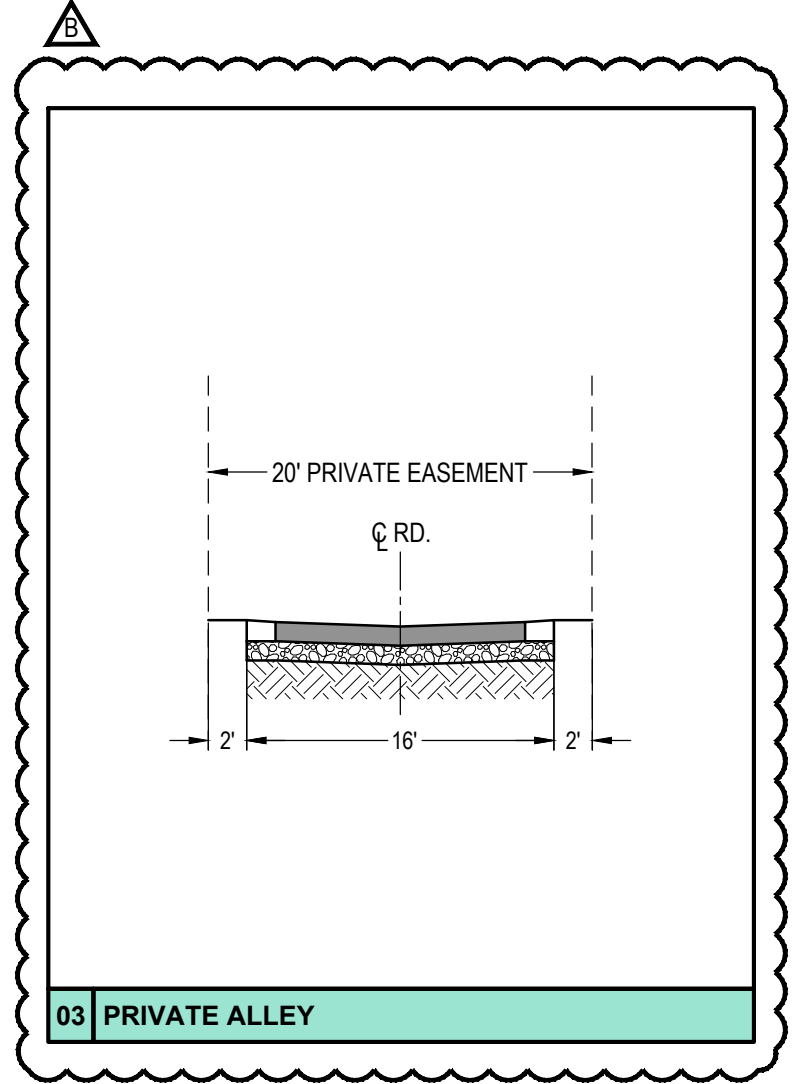

03 PRIVATE ALLEY

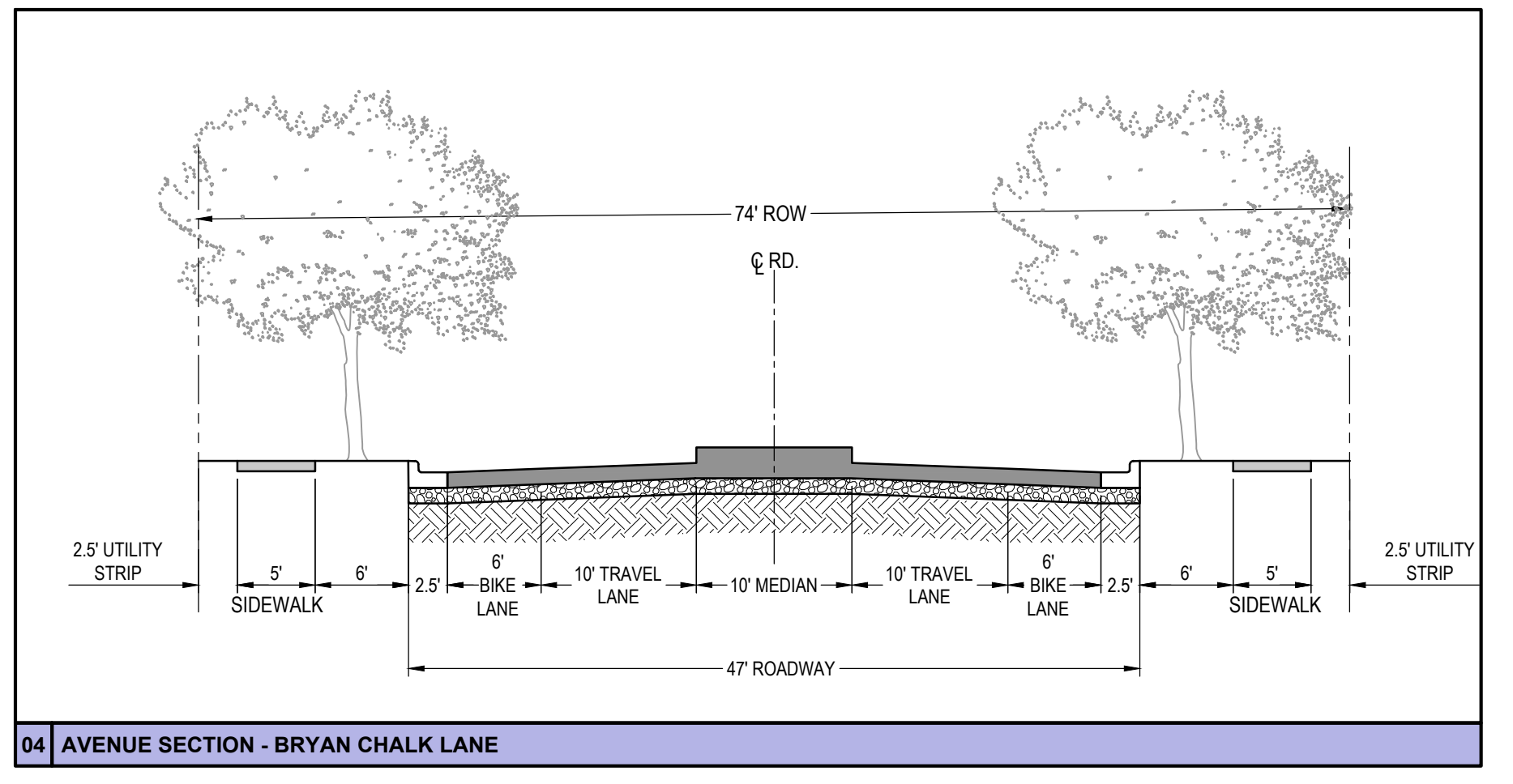

04 AVENUE SECTION - BRYAN CHALK LANE

REVISIONS	
A	02/22/2021 TOWN OF KNIGHTDALE COMMENTS
B	05/07/2021 TOWN OF KNIGHTDALE COMMENTS

STATUS	FOR REVIEW ONLY
DATE:	DECEMBER 17, 2020
FILE NO.:	2018-022
HORIZ. SCALE:	1" = 60'
ORIG. SHEET SIZE:	24 x 36

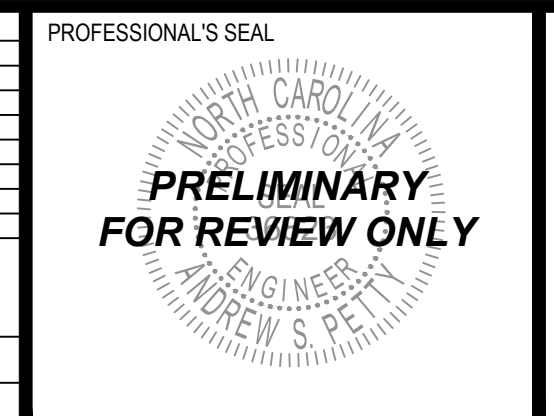

CONSULTANT

205 S. Fugate Avenue
Fayetteville, NC 27326

T: (919) 552-0840
F: (919) 552-2043

EST. 1910

NC LIC. NO. P-9799

CLIENT

Envision Homes
4441 Six Forks Road, Suite 106-117
Raleigh, NC 27609
919.389.7595 (m)
Contact: Josh Swindell
josh@envisionhomesnc.com

SKETCH PLAN REVIEW
FORESTVILLE YARD
STREET SECTIONS

SP-3.0

