

PLAN VIEW

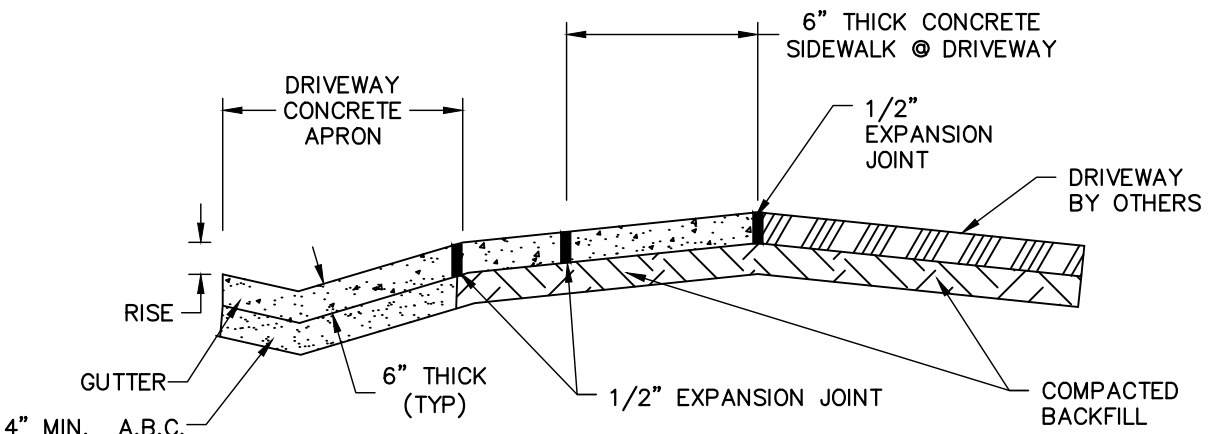

TYPICAL SECTION

NOTES:

1. RESIDENTIAL DRIVEWAYS TO BE 12' TO 18' WIDE AT RIGHT-OF-WAY.
2. COMMERCIAL DRIVEWAYS TO BE A MAXIMUM OF 36' WIDE AT RIGHT-OF-WAY.
3. CONCRETE SHALL BE 3000 P.S.I.
4. CONTROL JOINTS NOT TO EXCEED 10' ON CENTER.
5. CURB RADIUS SHALL NOT RISE MORE THAN 1 (ONE) INCH.
6. IF THE DRIVEWAY SECTION BETWEEN THE SIDEWALK AND THE DRIVEWAY APRON IS 18" OR LESS THE SIDEWALK WILL BE WIDENED TO THE APRON AND AN EXPANSION JOINT ELIMINATED.
7. DRIVEWAY SHALL BE A MINIMUM OF 2 FEET FROM PROPERTY LINES.

REVISIONS	
DATE	DESCRIPTION

TOWN OF KNIGHTDALE  
STANDARD DETAILS

STANDARD DRIVEWAY APRON

STD. NO.  
4.03