

**SMALL RADIUS
LESS THAN 15'**

CONCRETE DEPTH	
SIDE RAMPS	4"
LANDING & CURB RAMPS	6"

- ① 8.33% (12:1) MAX RAMP SLOPE
- ② CROSS SLOPE: 2.00%
- ③ CURB RAMPS REQUIRE A (4'-0") MINIMUM LANDING WITH A MAXIMUM CROSS SLOPE AND LONGITUDINAL SLOPE OF 2.00% WHERE PEDESTRIANS PERFORM TURNING MANEUVERS. SLOPE TO DRAIN TO CURB.
- ④ RAMPS SHALL BE INSTALLED THE SAME WIDTH AS THE SIDEWALK.

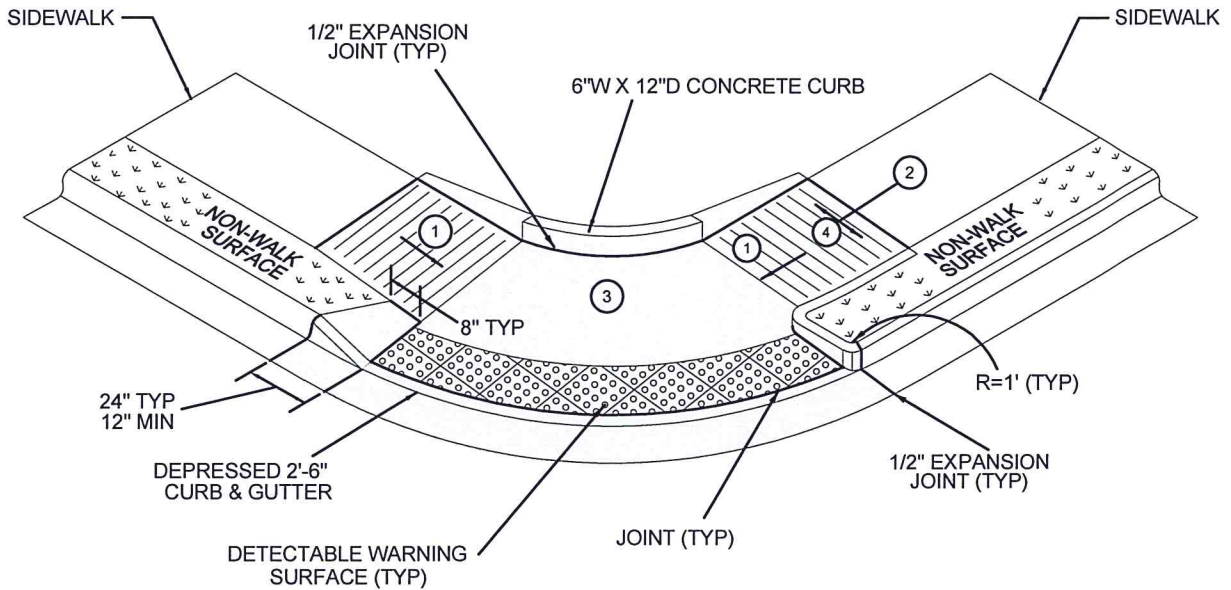

**LARGER RADIUS
15' OR GREATER**

PAY LIMITS FOR CURB RAMP

**ONLY TO BE USED WITH
TOWN OF KNIGHTDALE APPROVAL.**

REVISIONS	
DATE	DESCRIPTION

TOWN OF KNIGHTDALE
STANDARD DETAILS

SHARED CURB RAMPS/FLARED
(RETROFIT)

6 of 8
STD. NO.
4.06-6