

REVISIONS	
DATE	DESCRIPTION

TOWN OF KNIGHTDALE
STANDARD DETAILS

STANDARD REINFORCED CONCRETE
HEADWALL WITH WINGWALLS

1 of 2

STD. NO.

5.06

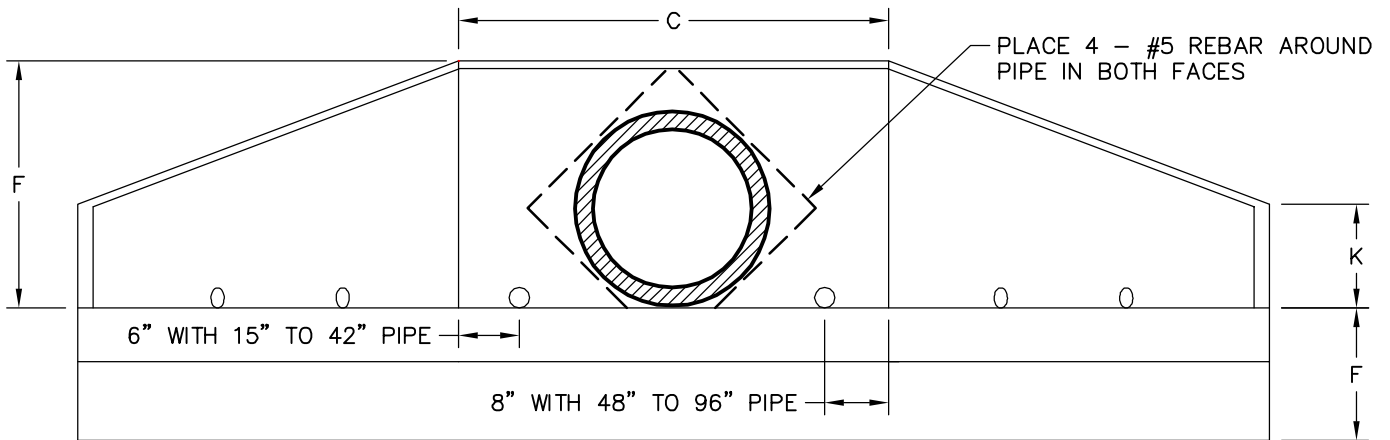

FRONT ELEVATION

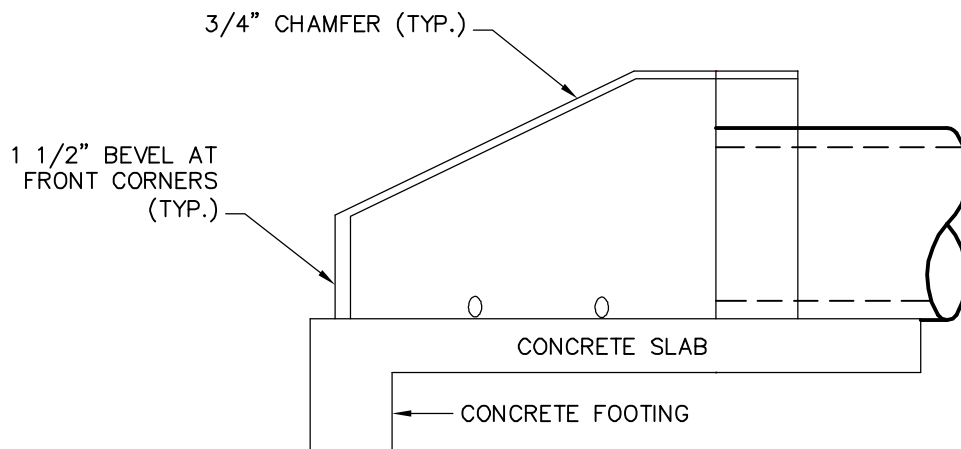

LEFT SIDE ELEVATION

NOTES:

1. SEE STANDARD DETAIL. 5.09 FOR DIMENSIONS.
2. PLACE 1 CUBIC FOOT OF WASHED STONE BEHIND EACH WEEP HOLE.

REVISIONS	
DATE	DESCRIPTION