

MERRITT HINTON OAKS BLVD

OFFSITE IMPROVEMENTS

ZMA-3-20

LOCATION: KNIGHTDALE BLVD FROM APPROX 735' WEST OF HINTON OAKS BLVD TO THE INTERSECTION WITH HINTON OAKS BLVD.
 HINTON OAKS BLVD FROM THE INTERSECTION WITH KNIGHTDALE BLVD TO APPROX 605' NORTH OF KNIGHTDALE BLVD.

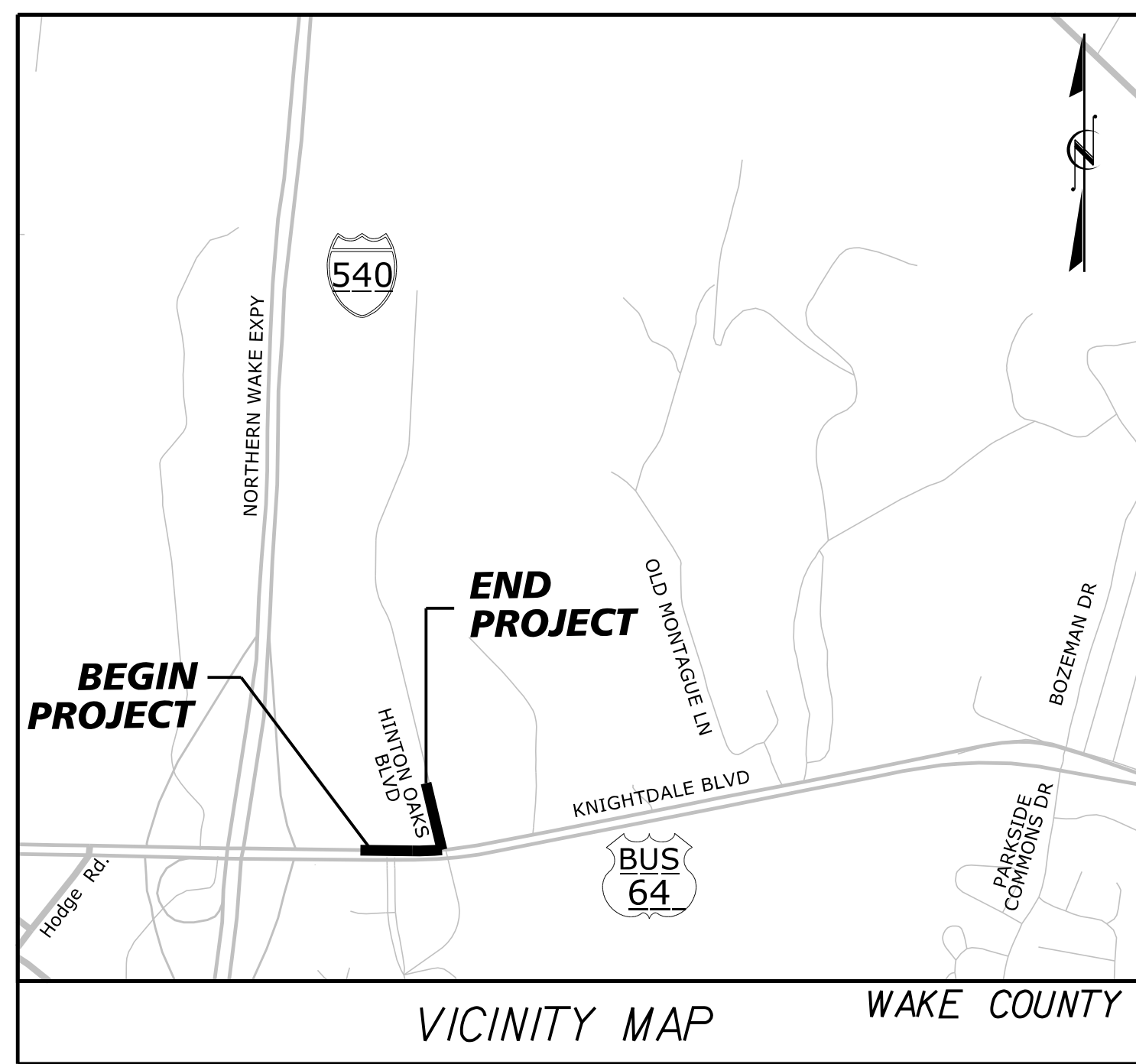
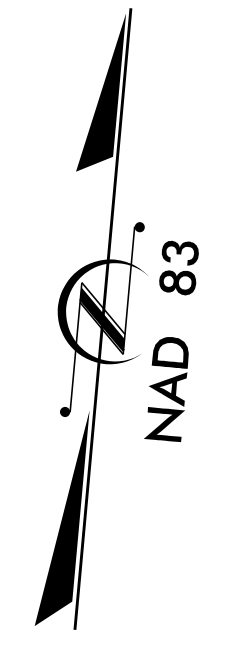

VICINITY MAP
WAKE COUNTY
NOT TO SCALE

DEVELOPER:
 MERRITT PROPERTIES, LLC
 2066 LORD BALTIMORE DRIVE
 BALTIMORE, MD, 21244
 NATHAN ROBB
 nrobb@merrittproperties.com

ENGINEER:
 KIMLEY-HORN AND ASSOCIATES, INC.
 300 MORRIS ST, SUITE 200
 DURHAM, NC 27701
 TYLER WHITE, P.E.
 919.677.2074
 tylerwhite@kimley-horn.com

SURVEYOR:
 MCKIM & CREED
 1730 VARSITY DRIVE, VENTURE IV BUILDING
 SUITE 500
 RALEIGH, NC 27606
 JEFFREY D. AKER, PLS
 919.233.8091
 jaker@mckimcreed.com

PUBLIC IMPROVEMENTS QUANTITIES

ITEM	UNIT	QUANTITY
PUBLIC WATER STUB	EA	4

INDEX OF SHEETS

SHEET NO.	DESCRIPTION
R0.00	TITLE SHEET
R0.01	PROJECT NOTES
R0.02	CONVENTIONAL SYMBOLS
R1.00	TYPICAL SECTIONS
R1.01	STAMPED ASPHALT CROSSWALK DETAIL
R1.02	DRAINAGE DETAIL
R1.03	DRAINAGE SUMMARY SHEET
R1.04 THRU R1.05	TOWN DETAILS
R1.06	GRAVITY RETAINING WALL NOTES & DETAILS
R1.07	EXISTING CONDITIONS
R2.00	PLAN VIEW
R2.01	PROFILE
R2.02	RETAINING WALL ENVELOPE
R3.00 THRU R3.05	TRAFFIC MANAGEMENT PLAN
R4.00	SIGNING AND MARKING PLAN
R5.00	EROSION CONTROL PLANS
R5.01 THRU R5.02	EROSION CONTROL DETAILS
R6.00 THRU R6.06	ROADWAY CROSS SECTIONS
L100	LANDSCAPE PLAN & DETAILS



This document, together with the concepts and designs presented herein, as an instrument of service, is intended only for the specific purpose and client for which it was prepared. Reuse or an improper reliance on this document without written authorization and adaptation by Kimley-Horn and Associates, Inc. shall be without liability to Kimley-Horn and Associates, Inc.

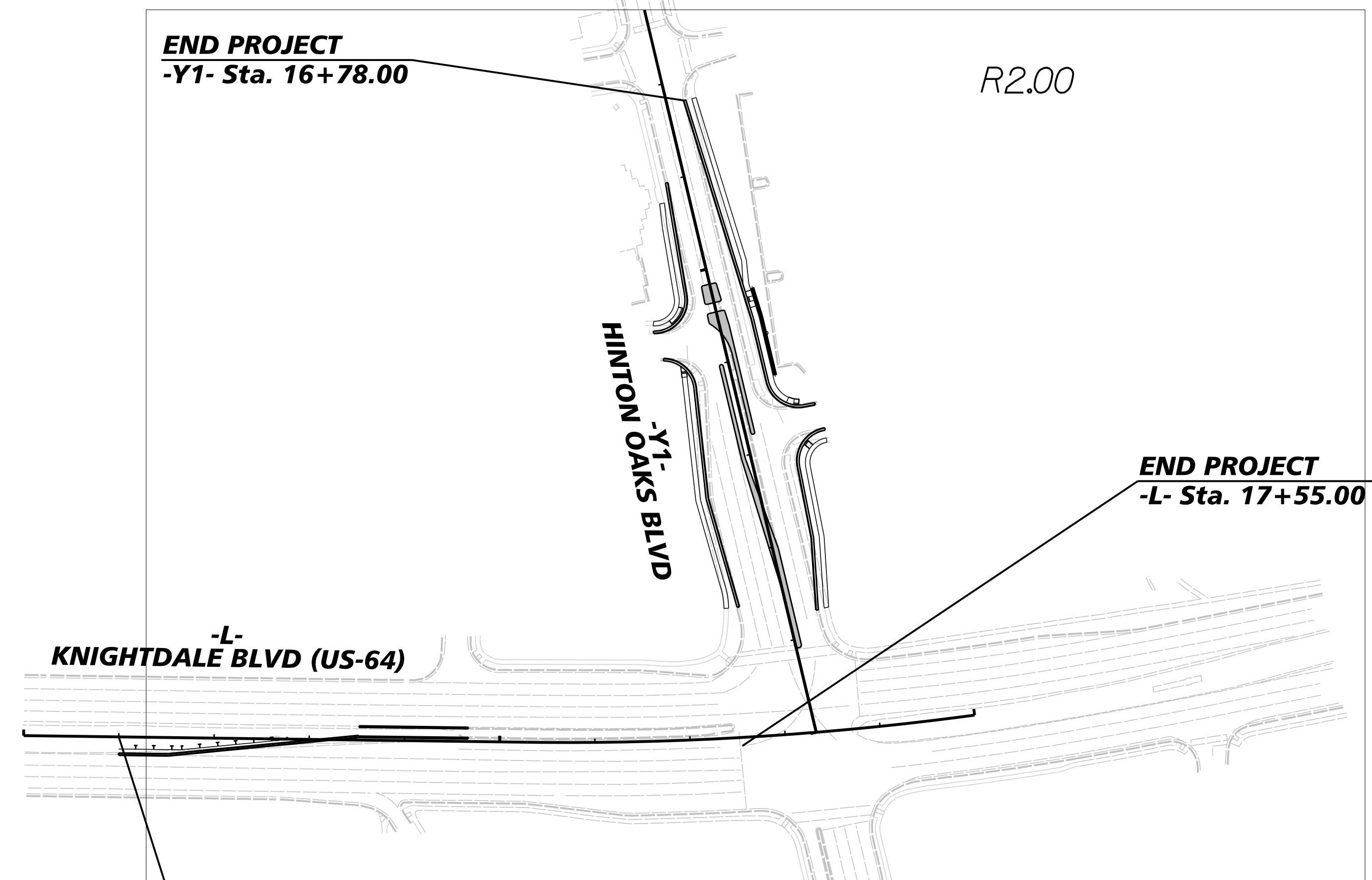

TO N SMITHFIELD ROAD

TO FLATROCK PARK DR

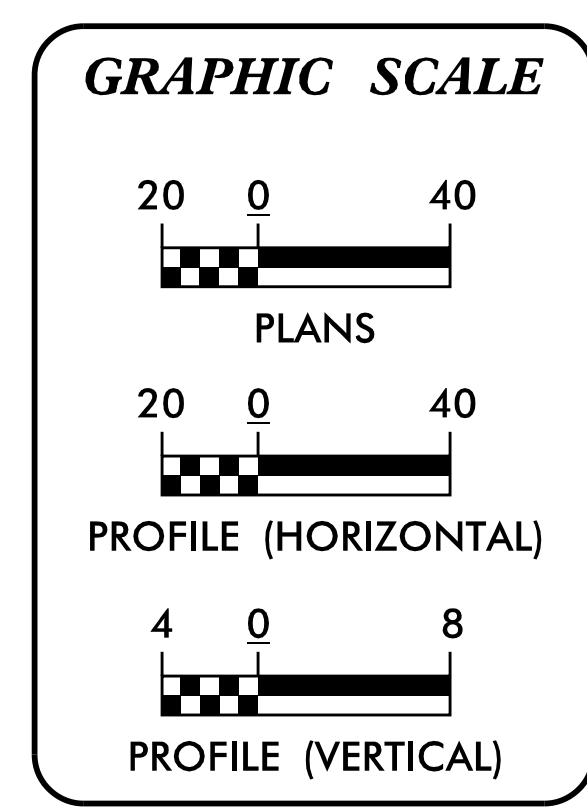

a. Town Approved Standards Shall Control. In the event of a conflict or inconsistency between these construction drawings and the Town of Knightdale's Approved Standards for this project, the Approved Standards shall control. Town of Knightdale Approved Standards shall mean all development documents necessary for approval for the Property including, but not limited to, any special use permit, subdivision plan, site plan, subdivision plat(s), phasing schedule, Development Agreement, Utility Allocation Agreement, Annexation Agreement, the Town of Knightdale Standard Specification and Details Manual and applicable provisions of the North Carolina State Building Code.

b. Professional Design Engineer Certification. These improvements shall be constructed in accordance with the following drawings and with the Standard Specifications of the Town of Knightdale:
 I, _____, P.E., certify that the Standard Specifications of the Town of Knightdale have been thoroughly checked and found to be applicable to this project. All exceptions to the applicable Town standards have been previously approved by the Town of Knightdale and said exceptions are shown on Sheet(s) _____ of these drawings.
 Seal: _____, P.E.
 Date: _____

c. Town Certification. This design has been reviewed by the Engineer for the Town of Knightdale, and to the best of my knowledge and belief, it conforms to the requirements established in the Standard Specifications of the Town of Knightdale.
 By: _____, Town Engineer
 Date: _____
 These plans are approved by the Town of Knightdale and serve as construction plans for this project.
 By: _____, Administrator
 Date: _____

CITY OF RALEIGH - PLANS AUTHORIZED FOR CONSTRUCTION

Electronic Approval: This approval is being issued electronically. This approval is valid only upon the signature of a City of Raleigh Review Officer below. The City will retain a copy of the approved plans. Any work authorized by this approval must proceed in accordance with the plans kept on file with the City. This electronic approval may not be edited once issued. Any modification to this approval once issued will invalidate this approval.

City of Raleigh Development Approval _____
 Raleigh Water Review Officer _____

Kimley-Horn
 © 2021
 300 MORRIS STREET, SUITE 200, DURHAM, NC, 27701
 PHONE: 919-682-3583
 WWW.KIMLEY-HORN.COM
 NC LICENSE #: F-0102



KHA PROJECT	013936008
DATE	4/4/2022
SCALE	AS SHOWN
DESIGNED BY:	TDW
DRAWN BY:	LCK
CHECKED BY:	TDW

TITLE SHEET

MERRITT HINTON OAKS BLVD OFFSITE IMPROVEMENTS
 NORTH CAROLINA
 KNIGHTDALE

SHEET NUMBER
R0.00

K:\DUR_Roadway\013936008 - Midway_Business_Park\Plan\Plan_Sheets\013936008_1.sht.dgn 4/4/2022

No.	REVISIONS	DATE	BY

K:\DUR_Roadway\013936008 - Midway Business Park\Plan\Plan Sheets\013936008_1.tshdgn 4/4/2022

GENERAL NOTES

- 1. WORK IN THIS PROJECT SHALL CONFORM TO THESE PLANS, THE LATEST EDITIONS OF THE NORTH CAROLINA DEPARTMENT OF TRANSPORTATION (NCDOT) ROAD AND BRIDGE SPECIFICATIONS, THE NCDOT ROAD AND BRIDGE STANDARDS, THE NORTH CAROLINA EROSION AND SEDIMENT CONTROL HANDBOOK, THE NORTH CAROLINA EROSION AND SEDIMENT CONTROL REGULATIONS, TOWN OF KNIGHTDALE SPECIFICATIONS, AND GENERAL DESIGN STANDARDS. IN THE EVENT OF CONFLICT BETWEEN ANY OF THESE STANDARDS, SPECIFICATIONS, OR PLANS, THE MOST STRINGENT SHALL GOVERN UNLESS OTHERWISE NOTED IN THESE PLANS.
2. THE CONTRACTOR SHALL BE SOLELY RESPONSIBLE FOR ALL JOBSITE SAFETY, INCLUDING BUT NOT LIMITED TO TRENCH SAFETY, DURING ALL PHASES OF CONSTRUCTION.
3. THE LOCATION AND SIZE OF EXISTING UTILITIES AS SHOWN IS APPROXIMATE ONLY. THE CONTRACTOR IS RESPONSIBLE FOR HORIZONTALLY AND VERTICALLY LOCATING AND PROTECTING ALL PUBLIC OR PRIVATE UTILITIES (SHOWN OR NOT SHOWN) WHICH LIE IN OR ADJACENT TO THE CONSTRUCTION SITE. AT LEAST 48 HOURS PRIOR TO ANY DEMOLITION, GRADING, OR CONSTRUCTION ACTIVITY, THE CONTRACTOR SHALL NOTIFY THE NORTH CAROLINA ONE-CALL UTILITIES LOCATION SERVICE (ULOCO) AT 1-800-632-4949 FOR PROPER IDENTIFICATION OF EXISTING UTILITIES WITHIN THE SITE.
4. THE CONTRACTOR SHALL SALVAGE AND PROTECT ALL EXISTING POWER POLES, SIGNS, MANHOLES, TELEPHONE RISERS, WATER VALVES, ETC. DURING ALL CONSTRUCTION PHASES. THE CONTRACTOR SHALL REPAIR, AT HIS OWN EXPENSE, ANY EXISTING UTILITIES DAMAGED DURING CONSTRUCTION.
5. TRAFFIC MANAGEMENT ON PUBLIC STREETS IS THE RESPONSIBILITY OF THE CONTRACTOR AND SHALL BE IN CONFORMANCE WITH THE TRAFFIC CONTROL PLAN, THE "MANUAL OF UNIFORM TRAFFIC CONTROL DEVICES," AND AS FURTHER DIRECTED BY THE TOWN AND STATE INSPECTORS.
6. ALL MANUFACTURERS' PRODUCTS SPECIFIED IN THESE PLANS OR USED AS APPROVED ALTERNATES SHALL BE INSTALLED PER THE MANUFACTURERS' SPECIFICATIONS.
7. ANY DISCREPANCIES FOUND BETWEEN THE DRAWINGS AND SPECIFICATIONS AND SITE CONDITIONS OR ANY INCONSISTENCIES OR AMBIGUITIES IN DRAWINGS OR SPECIFICATIONS SHALL BE IMMEDIATELY REPORTED TO THE ENGINEER, IN WRITING, WHO SHALL PROMPTLY ADDRESS SUCH INCONSISTENCIES OR AMBIGUITIES. WORK DONE BY THE CONTRACTOR AFTER HIS DISCOVERY OF SUCH DISCREPANCIES, INCONSISTENCIES, OR AMBIGUITIES SHALL BE DONE AT THE CONTRACTOR'S RISK.
8. CONSTRUCTION STAKEOUT FOR THIS PROJECT SHALL BE PROVIDED BY THE CONTRACTOR.
9. A PRE-CONSTRUCTION CONFERENCE SHALL BE HELD PRIOR TO THE START OF CONSTRUCTION. THE CONTRACTOR SHALL ARRANGE THE MEETING WITH NCDOT AND THE TOWN OF KNIGHTDALE.
10. CONTRACTOR IS RESPONSIBLE FOR VERIFYING OR OBTAINING ALL REQUIRED PERMITS AND APPROVALS PRIOR TO COMMENCING CONSTRUCTION. NCDOT ENCROACHMENTS SHALL BE OBTAINED BY THE ENGINEER.
11. THE FRAMES AND COVERS OF ALL EXISTING AND PROPOSED DRAINAGE, SANITARY SEWER, WATER MAIN, GAS, AND WIRE UTILITY STRUCTURES SHALL BE ADJUSTED TO MATCH PROPOSED FINISHED ELEVATIONS AND SLOPES.
12. ROADWAYS MUST BE CAPABLE OF SUPPORTING FIRE APPARATUS DURING CONSTRUCTION.
13. ALL CONSTRUCTION SHALL BE IN ACCORDANCE WITH CURRENT NCDOT STANDARDS, SPECIFICATIONS, DETAILS AND ENCROACHMENT AGREEMENTS.
14. NO CHANGES TO ANY ASPECT OF THIS ROADWAY PLAN, INCLUDING BUT NOT LIMITED TO, LANDSCAPING, GRADING, BUILDING ELEVATIONS, LIGHTING, OR UTILITIES WILL BE MADE WITHOUT THE APPROVAL OF NCDOT.
15. CONTRACTOR TO ENSURE THAT ALL STREETS WITHIN THE LIMITS OF THE PROJECT AND IN FRONT OF THE PROJECT ARE KEPT CLEAN AT ALL TIMES OR A WASH STATION WILL BE REQUIRED.
16. ALL STORM DRAIN FRAMES & GRATES SHALL BE STAMPED WITH "DRAINS TO RIVER" PER CITY OF RALEIGH STANDARDS.
17. LIMITS OF OFFSITE IMPROVEMENTS NOT WITHIN FLOODPLAIN.

UTILITY NOTES

- 1. WATER VALVE BOXES THAT ARE ENCOUNTERED WITHIN THE PROJECT LIMITS ARE TO BE RAISED OR LOWERED TO MATCH THE ADJACENT FINISHED WORK.
2. WATER METER BOXES THAT ARE ENCOUNTERED WITHIN THE PROJECT LIMITS OUTSIDE THE PROPOSED PAVEMENT SECTION ARE TO BE RAISED OR LOWERED TO MATCH THE ADJACENT FINISHED WORK.
3. WATER METER BOXES THAT ARE ENCOUNTERED WITHIN THE PROPOSED PAVEMENT SECTION ARE TO BE RELOCATED OUT OF THE PROPOSED PAVEMENT.

GRADING

- 1. THE GRADE LINES SHOWN DENOTE THE FINISHED ELEVATION OF THE PROPOSED SURFACING AT GRADE POINTS SHOWN ON THE TYPICAL SECTIONS. GRADE LINES MAY BE ADJUSTED AT THEIR BEGINNING AND ENDING AND AT STRUCTURES AND EXISTING PAVEMENT AS DIRECTED BY THE ENGINEER IN ORDER TO SECURE A PROPER TIE-IN.
2. REFER TO EROSION CONTROL SHEETS FOR CLEARING LIMITS AND TEMPORARY EROSION CONTROL DEVICES TO BE INSTALLED PRIOR TO COMMENCING CONSTRUCTION.
3. EROSION AND SEDIMENT CONTROL MEASURES SHALL BE MAINTAINED CONTINUOUSLY, RELOCATED WHEN AND AS NECESSARY, AND SHALL BE CHECKED AFTER EVERY RAINFALL. SEEDED AREAS SHALL BE CHECKED REGULARLY AND SHALL BE WATERED, FERTILIZED, RESEEDED, AND MULCHED AS NECESSARY TO OBTAIN A DENSE STAND OF GRASS.
4. ALL AREAS SHALL BE GRADED FOR POSITIVE DRAINAGE, AND AS SHOWN ON THESE PLANS. THE CONTRACTOR SHALL MAINTAIN ADEQUATE SITE DRAINAGE DURING ALL PHASES OF CONSTRUCTION. IN ADDITION TO THE MEASURES SHOWN IN THESE PLANS, THE CONTRACTOR SHALL USE INTERIM SILT FENCES, DIVERSION DITCHES, BERMS, OR OTHER METHODS AS REQUIRED TO DIRECT DRAINAGE AS SHOWN ON THESE PLANS, TO BEST UTILIZE THE EROSION CONTROL DEVICES IN PLACE, AND TO PREVENT SILT AND CONSTRUCTION DEBRIS FROM FLOWING ONTO ADJACENT PROPERTIES. CONTRACTOR SHALL COMPLY WITH ALL APPLICABLE STATE AND LOCAL EROSION, CONSERVATION, AND SILTATION ORDINANCES. CONTRACTOR SHALL REMOVE ALL TEMPORARY EROSION CONTROL DEVICES UPON COMPLETION OF PERMANENT DRAINAGE FACILITIES AND THE ESTABLISHMENT OF A STAND OF GRASS OR OTHER GROWTH TO PREVENT EROSION.
5. GRADING CONTRACTOR SHALL COORDINATE WITH THE UTILITY COMPANIES FOR ANY REQUIRED UTILITY ADJUSTMENTS AND/OR RELOCATIONS.
6. ALL MATERIALS USED FOR BACKFILL SHALL BE FREE OF WOOD, ROOTS, ROCKS, BOULDERS, OR ANY OTHER NON-COMPATIBLE SOIL TYPE MATERIAL. UNSATISFACTORY MATERIALS ALSO INCLUDE MAN-MADE FILLS AND REFUSE DEBRIS DERIVED FROM ANY SOURCE.
7. ALL GRADING / SOIL COMPACTION OPERATIONS WITHIN THE LIMITS OF STATE RIGHT OF WAYS SHALL ADHERE TO NCDOT REQUIREMENTS, IN ACCORDANCE WITH AASHTO T99 AS MODIFIED BY THE DEPARTMENT. COPIES OF THESE MODIFIED TESTING PROCEDURES ARE AVAILABLE UPON REQUEST FROM THE DEPARTMENT'S MATERIALS AND TESTS UNIT.
8. ALL DEMOLITION DEBRIS AND OTHER EXCESS MATERIAL SHALL BE HAULED OFF-SITE AS DIRECTED BY THE OWNER AND PROPERLY DISPOSED OF.
9. PROPOSED CONTOURS AND GUTTER GRADIENTS ARE APPROXIMATE. PROPOSED ROADWAY PROFILES/SUPERELEVATIONS ARE TO BE USED IN CASE OF DISCREPANCY.
10. REFER TO ROADWAY PLAN FOR HORIZONTAL DIMENSIONS.
11. WHERE FILL IS TO BE PLACED ON EXISTING SLOPES STEEPER THAN 4:1, CONTRACTOR SHALL EXCAVATE BENCHES WITH A MAXIMUM DEPTH OF 3'.
12. THE CONTRACTOR SHALL OBTAIN ALL PERMITS REQUIRED FOR BLASTING ROCK IF BLAST ROCK IS ENCOUNTERED. CONTRACTOR SHALL BE SOLELY RESPONSIBLE FOR COMPLYING WITH ALL BLASTING AND SAFETY REQUIREMENTS.
13. TREE PROTECTION FENCING SHALL BE INSTALLED AND INSPECTED BEFORE THE GRADING PERMIT IS ISSUED.
14. CROSS SLOPES AND ELEVATIONS SHOWN ON CROSS SECTIONS ARE APPROXIMATE. PROPOSED PAVEMENT CROSS SLOPES ARE TO BE BASED ON EXISTING CROSS SLOPE DETERMINED IN FIELD. IF FIELD CONDITIONS VARY FROM THOSE SHOWN ON PLANS, NOTIFY ENGINEER IMMEDIATELY.

PAVING / CURBING

- 1. WHERE PROPOSED CURB AND GUTTER TIES TO EXISTING CURB OR CURB AND GUTTER, A TRANSITION OF 10' SHALL BE MADE TO CONFORM TO THE EXISTING HEIGHTS AND SHAPES.
2. BEFORE ANY EARTHWORK IS DONE, THE CONTRACTOR SHALL STAKE OUT AND MARK THE LIMITS OF PAVEMENT AND OTHER ITEMS ESTABLISHED IN THE PLANS. THE CONTRACTOR SHALL PROVIDE ALL NECESSARY ENGINEERING AND SURVEYING FOR LINE AND GRADE CONTROL POINTS RELATED TO EARTHWORK.
3. ALL PAVEMENT SUB GRADES SHALL BE SCARIFIED TO A DEPTH OF 8 INCHES AND COMPACTED TO A MINIMUM DENSITY OF 100 PERCENT OF ASTM D-1557 DENSITY AT OPTIMUM MOISTURE CONTENT UNLESS OTHERWISE SHOWN ON THE CONSTRUCTION PLANS OR AS DIRECTED BY THE GEOTECHNICAL ENGINEER. FILL SHALL BE PLACED AND COMPACTED IN MAXIMUM 8" LIFTS. IN AREAS WHERE ROCK IS ENCOUNTERED AT FINAL SUB GRADE ELEVATION, THE EXPOSED ROCK SHALL BE TOPPED WITH A LEVELING COURSE OF SANDY CLAY OR CLAYEY SAND (P.I. BETWEEN 4 AND 15) AS NEEDED TO PROVIDE A SMOOTH SURFACE FOR PAVING.
4. THE CONTRACTOR SHALL CLEAR AND GRUB THE SITE AND PLACE, COMPACT, AND MOISTURE CONDITION ALL FILL PER THE PROJECT GEOTECHNICAL ENGINEER'S SPECIFICATIONS. THE FILL MATERIAL TO BE USED SHALL BE APPROVED BY THE GEOTECHNICAL ENGINEER PRIOR TO PLACEMENT.
5. ALL CURB JOINTS SHALL EXTEND THROUGH THE CURB. MINIMUM LENGTH OF OFFSET JOINTS AT RADIUS POINTS IS 1.5 FEET. ALL JOINTS SHALL BE SEALED WITH JOINT SEALANT.
6. TESTING OF MATERIALS REQUIRED FOR THE CONSTRUCTION OF THE PAVING IMPROVEMENTS SHALL BE PERFORMED BY AN APPROVED AGENCY FOR TESTING MATERIALS. THE NOMINATION OF THE TESTING LABORATORY AND THE PAYMENT OF SUCH TESTING SERVICES SHALL BE MADE BY THE OWNER. IT SHALL BE THE CONTRACTOR'S RESPONSIBILITY TO SHOW BY STANDARD TESTING PROCEDURES THAT THE WORK CONSTRUCTED DOES MEET THE REQUIREMENTS OF THE NCDOT SPECIFICATIONS.
7. ALL REINFORCING STEEL SHALL BE NEW DOMESTIC BILLET STEEL CONFORMING TO ASTM A-615, GRADE 60, AND SHALL BE SUPPORTED BY BAR CHAIRS.
8. ALL SIGNS, PAVEMENT MARKINGS, AND OTHER TRAFFIC CONTROL DEVICES ON PUBLIC STREETS SHALL CONFORM TO MUTCD, AND NCDOT STANDARDS.
9. ALL HANDICAP RAMPING, STRIPING, AND PAVEMENT MARKINGS SHALL CONFORM TO ADA REQUIREMENTS AND THE "NORTH CAROLINA STATE BUILDING CODE, VOL. I-C ACCESSIBILITY CODE." ALL RAMPS SHALL COMPLY WITH THE LATEST NCDOT STANDARDS. WHEELCHAIR RAMPS ARE SHOWN ON THE PLANS AT APPROXIMATE LOCATIONS.
10. CONTRACTOR SHALL SAWCUT & REMOVE ANY THE EXISTING PAVEMENT WHEN THE EXISTING PAVEMENT IS BEING WIDENED OR WHERE NEW CURB AND GUTTER IS PROPOSED.
11. ALL CURVES ON THIS PROJECT SHALL BE SUPERELEVATED IN ACCORDANCE WITH STD. 225.04 & 225.05 USING THE RATE OF SUPERELEVATION AND RUNOFF SHOWN ON THE PLANS. SUPERELEVATION IS TO BE REVOLVED ABOUT THE GRADE POINTS SHOWN ON THE TYPICAL SECTIONS.

4. Town Certification. This design has been reviewed by the Engineer for the Town of Knightdale, and to the best of my knowledge and belief, it conforms to the requirements established in the Standard Specifications of the Town of Knightdale.
By: [Signature] Date: [Blank]
Town Engineer
These plans are approved by the Town of Knightdale and serve as construction plans for this project.
By: [Signature] Date: [Blank]
Administrator

Table with 10 columns and 1 row, containing empty cells for project details.

Kimley-Horn logo and contact information: 300 MORRIS STREET, SUITE 200, DURHAM, NC, 27701. PHONE: 919-682-3883. WWW.KIMLEY-HORN.COM. NC LICENSE # F-0102



Table with 2 columns: KHA PROJECT (013936008), DATE (4/4/2022), SCALE (N/T/S), DESIGNED BY (TDW), DRAWN BY (LCK), CHECKED BY (TDW).

PROJECT NOTES

MERRITT HINTON OAKS BLVD OFFSITE IMPROVEMENTS NORTH CAROLINA KNIGHTDALE

SHEET NUMBER R0.01

Note: Not to Scale

*S.U.E. = Subsurface Utility Engineering

STATE OF NORTH CAROLINA
DIVISION OF HIGHWAYS

CONVENTIONAL PLAN SHEET SYMBOLS

BOUNDARIES AND PROPERTY:

Table listing symbols for boundaries and property: State Line, County Line, Township Line, City Line, Reservation Line, Property Line, Existing Iron Pin, Property Corner, Property Monument, Parcel/Sequence Number, Existing Fence Line, Proposed Woven Wire Fence, Proposed Chain Link Fence, Proposed Barbed Wire Fence, Existing Wetland Boundary, Proposed Wetland Boundary, Existing Endangered Animal Boundary, Existing Endangered Plant Boundary.

BUILDINGS AND OTHER CULTURE:

Table listing symbols for buildings and other culture: Gas Pump Vent or U/G Tank Cap, Sign, Well, Small Mine, Foundation, Area Outline, Cemetery, Building, School, Church, Dam.

HYDROLOGY:

Table listing symbols for hydrology: Stream or Body of Water, Hydro, Pool or Reservoir, Jurisdictional Stream, Buffer Zone 1, Buffer Zone 2, Flow Arrow, Disappearing Stream, Spring, Swamp Marsh, Proposed Lateral, Tail, Head Ditch, False Sump.

RAILROADS:

Table listing symbols for railroads: Standard Gauge, RR Signal Milepost, Switch, RR Abandoned, RR Dismantled.

RIGHT OF WAY:

Table listing symbols for right of way: Baseline Control Point, Existing Right of Way Marker, Existing Right of Way Line, Proposed Right of Way Line, Proposed Right of Way Line with Iron Pin and Cap Marker, Proposed Right of Way Line with Concrete or Granite Marker.

Table listing symbols for easements: Existing Control of Access, Proposed Control of Access, Existing Easement Line, Proposed Temporary Construction Easement, Proposed Temporary Drainage Easement, Proposed Permanent Drainage Easement, Proposed Permanent Utility Easement.

ROADS AND RELATED FEATURES:

Table listing symbols for roads and related features: Existing Edge of Pavement, Existing Curb, Proposed Slope Stakes Cut, Proposed Slope Stakes Fill, Proposed Wheel Chair Ramp, Curb Cut for Future Wheel Chair Ramp, Existing Metal Guardrail, Proposed Guardrail, Existing Cable Guiderail, Proposed Cable Guiderail, Equality Symbol, Pavement Removal.

VEGETATION:

Table listing symbols for vegetation: Single Tree, Single Shrub, Hedge, Woods Line, Orchard, Vineyard.

EXISTING STRUCTURES:

Table listing symbols for existing structures: MAJOR: Bridge, Tunnel or Box Culvert, Bridge Wing Wall, Head Wall and End Wall; MINOR: Head and End Wall, Pipe Culvert, Footbridge, Drainage Box: Catch Basin, DI or JB, Paved Ditch Gutter, Storm Sewer Manhole, Storm Sewer.

UTILITIES:

Table listing symbols for utilities: POWER: Existing Power Pole, Proposed Power Pole, Existing Joint Use Pole, Proposed Joint Use Pole, Power Manhole, Power Line Tower, Power Transformer, U/G Power Cable Hand Hole, H-Frame Pole, Recorded U/G Power Line, Designated U/G Power Line (S.U.E.*); TELEPHONE: Existing Telephone Pole, Proposed Telephone Pole, Telephone Manhole, Telephone Booth, Telephone Pedestal, Telephone Cell Tower, U/G Telephone Cable Hand Hole, Recorded U/G Telephone Cable, Designated U/G Telephone Cable (S.U.E.*), Recorded U/G Telephone Conduit, Designated U/G Telephone Conduit (S.U.E.*), Recorded U/G Fiber Optics Cable, Designated U/G Fiber Optics Cable (S.U.E.*).

WATER:

Table listing symbols for water: Water Manhole, Water Meter, Water Valve, Water Hydrant, Recorded U/G Water Line, Designated U/G Water Line (S.U.E.*), Above Ground Water Line.

TV:

Table listing symbols for TV: TV Satellite Dish, TV Pedestal, TV Tower, U/G TV Cable Hand Hole, Recorded U/G TV Cable, Designated U/G TV Cable (S.U.E.*), Recorded U/G Fiber Optic Cable, Designated U/G Fiber Optic Cable (S.U.E.*).

GAS:

Table listing symbols for gas: Gas Valve, Gas Meter, Recorded U/G Gas Line, Designated U/G Gas Line (S.U.E.*), Above Ground Gas Line.

SANITARY SEWER:

Table listing symbols for sanitary sewer: Sanitary Sewer Manhole, Sanitary Sewer Cleanout, U/G Sanitary Sewer Line, Above Ground Sanitary Sewer, Recorded SS Forced Main Line, Designated SS Forced Main Line (S.U.E.*).

MISCELLANEOUS:

Table listing miscellaneous symbols: Utility Pole, Utility Pole with Base, Utility Located Object, Utility Traffic Signal Box, Utility Unknown U/G Line, U/G Tank; Water, Gas, Oil, A/G Tank; Water, Gas, Oil, U/G Test Hole (S.U.E.*), Abandoned According to Utility Records, End of Information.

4. Town Certification. This design has been reviewed by the Engineer for the Town of Knightdale, and to the best of my knowledge and belief, it conforms to the requirements established in the Standard Specifications of the Town of Knightdale.
By: _____ Date: _____
Town Engineer
These plans are approved by the Town of Knightdale and serve as construction plans for this project.
By: _____ Date: _____
Administrator

K:\DUR_Roadway\013936008 - Midway Business Park\Plan\Plan Sheets\013936008_1.tsd.dgn 4/4/2022

Project information and title block including: KIMLEY HORN logo, project name (MERRITT HINTON OAKS BLVD OFFSITE IMPROVEMENTS), location (NORTH CAROLINA), sheet number (R0.02), and revision table.

PAVEMENT SCHEDULE	
C1	PROPOSED APPROX. 1.5" ASPHALT CONCRETE SURFACE COURSE TYPE S9.5C, AT AN AVERAGE RATE OF 168 LBS. PER SQ. YD.
C2	PROPOSED APPROX. 3" ASPHALT CONCRETE SURFACE COURSE TYPE S9.5C, AT AN AVERAGE RATE OF 168 LBS. PER SQ. YD. IN EACH OF TWO LAYERS.
D1	PROPOSED APPROX. 4" ASPHALT CONCRETE INTERMEDIATE COURSE, TYPE I9.0C, AT AN AVERAGE RATE OF 456 LBS. PER SQ. YD.
E1	PROPOSED APPROX. 5" ASPHALT CONCRETE BASE COURSE, TYPE B25.0C, AT AN AVERAGE RATE OF 570 LBS. PER SQ. YD.
J1	PROPOSED 6" SIDEWALK SUB BASE, 70 PERCENT NO. 57 STONE AND ASTM C33 SAND OR EQUIVALENT.
R1	PROPOSED 1'-6" CONCRETE CURB AND GUTTER
R2	PROPOSED 2'-6" CONCRETE CURB AND GUTTER
R3	PROPOSED MONOLITHIC 5' ISLAND (KEYED-IN 3", NCDOT STD. DRAWING 852.02)
R4	PROPOSED 2" CONCRETE CURB AND GUTTER
S	PROPOSED 4" CONCRETE SIDEWALK
T	EARTH MATERIAL
U	EXISTING ASPHALT PAVEMENT

NOTES:
1. REFER TO PLAN SHEETS FOR VARIABLE WIDTHS.

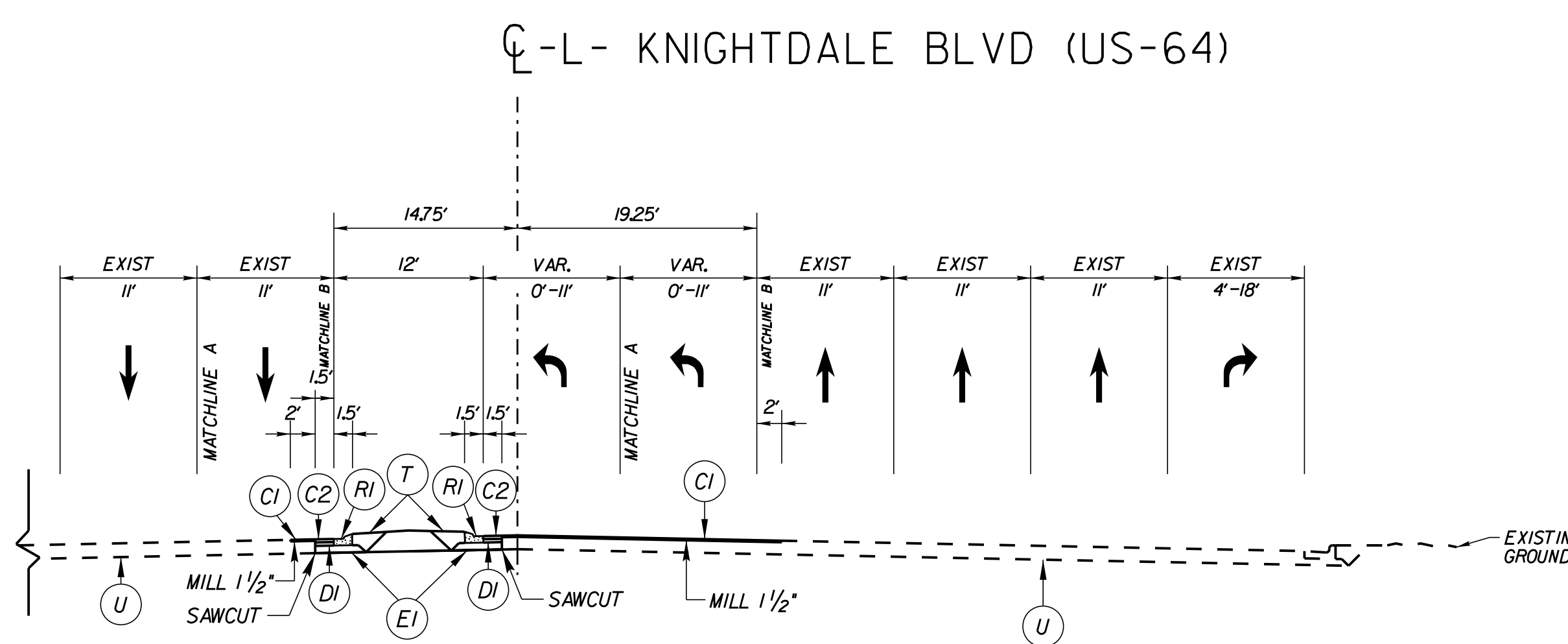

TYPICAL SECTION NO. 1
-L- STA 11+00.00 TO STA 17+52.00

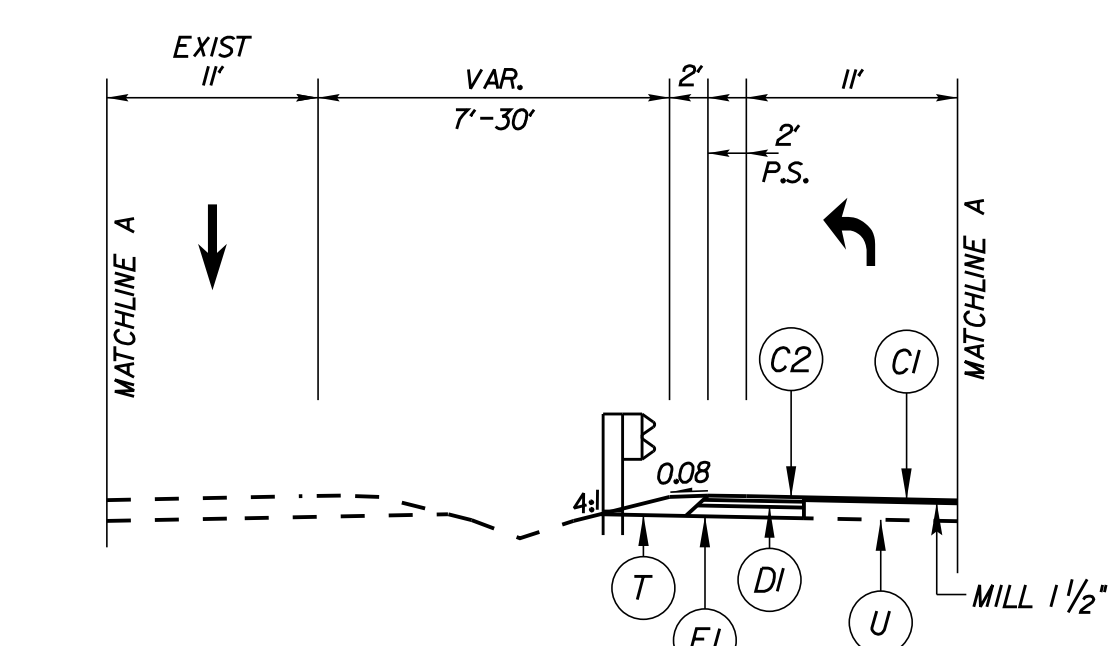

TYPICAL SECTION NO. 1A
-L- STA 11+00.00 TO STA 13+52.00

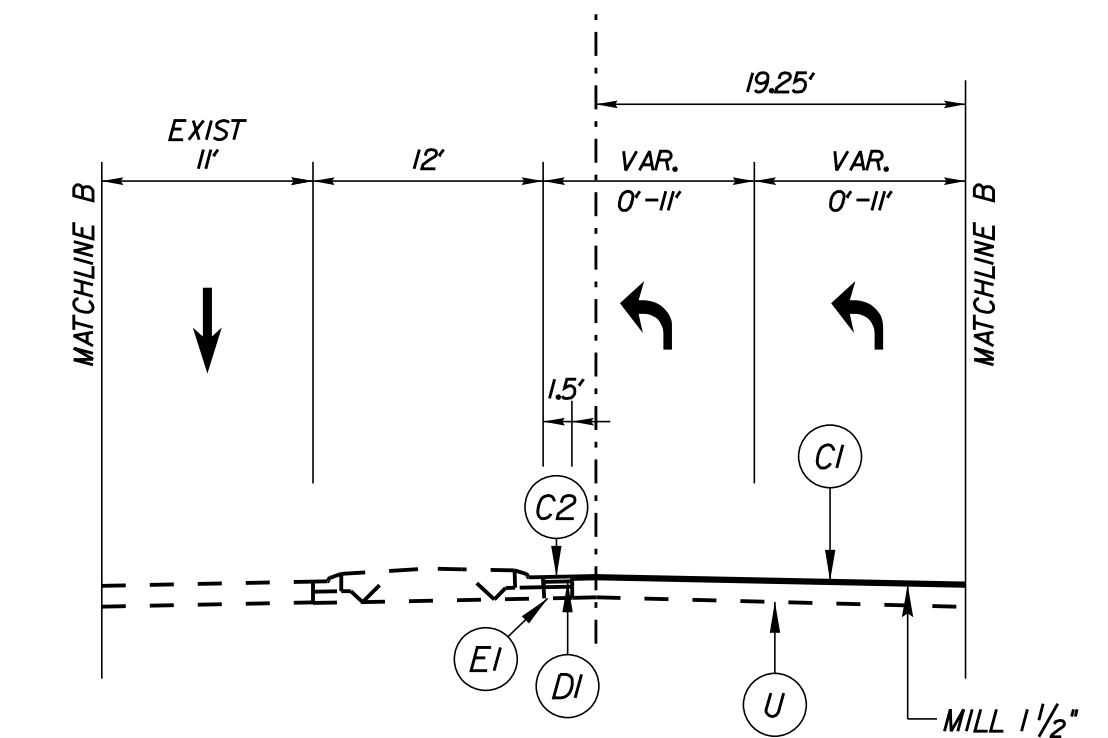

TYPICAL SECTION NO. 1B
-L- STA 14+67.00 TO STA 17+52.00

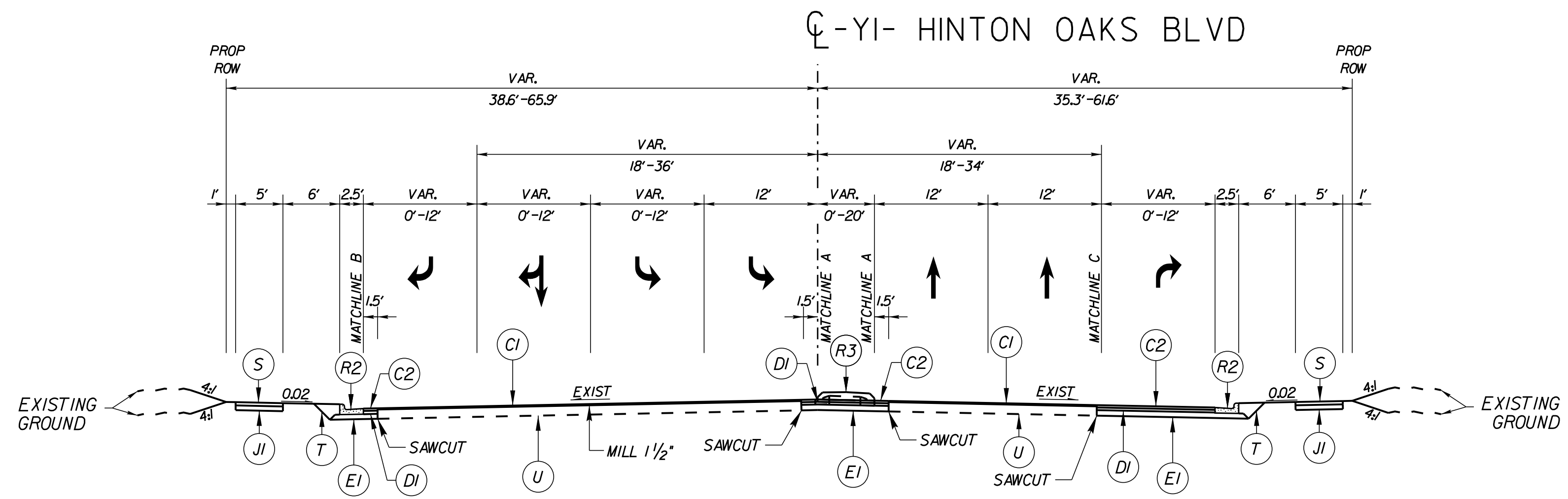

TYPICAL SECTION NO. 2
-Y1- STA 10+72.00 TO STA 16+78.00

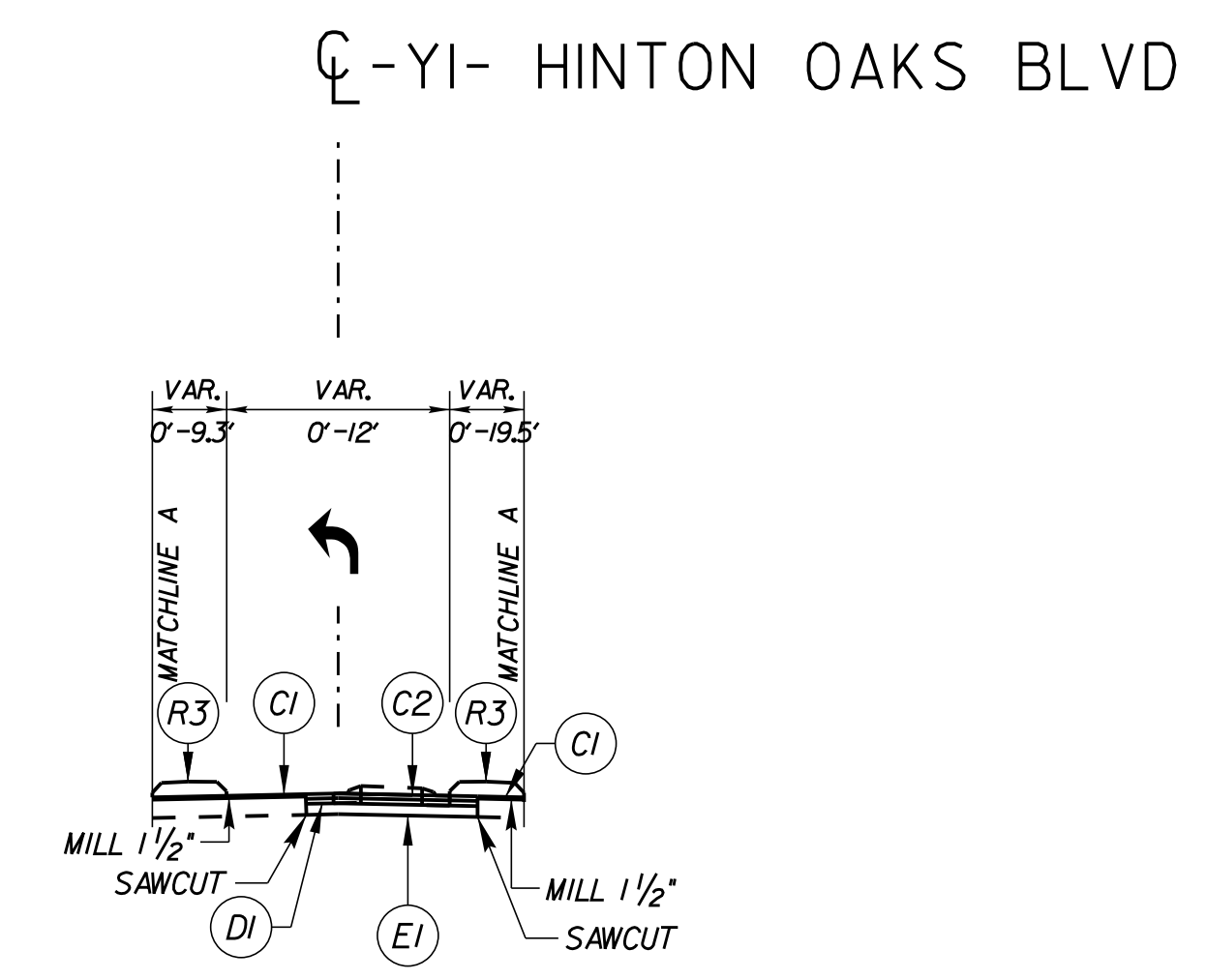

TYPICAL SECTION NO. 2A
-Y1- STA 11+97.00 TO STA 14+44.52

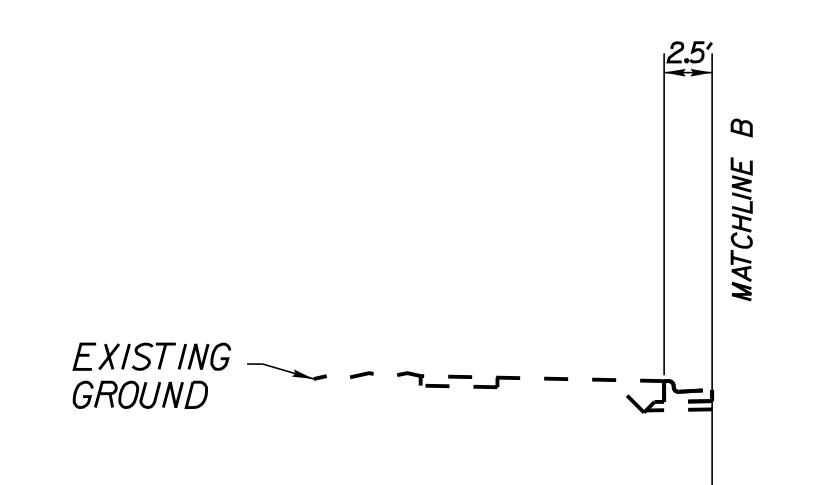

TYPICAL SECTION NO. 2B
-Y1- STA 10+72.00 TO STA 11+47.00
-Y1- STA 15+98.00 TO STA 16+78.00

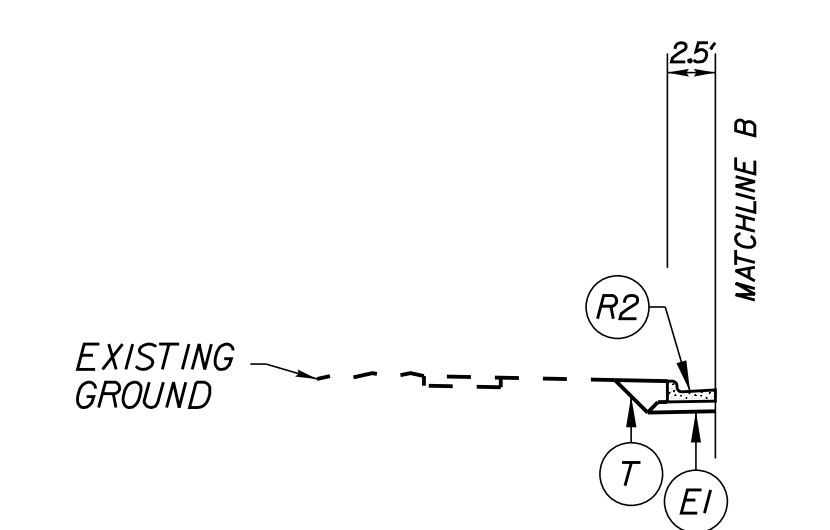

TYPICAL SECTION NO. 2C
-Y1- STA 15+78.00 TO STA 15+98.00

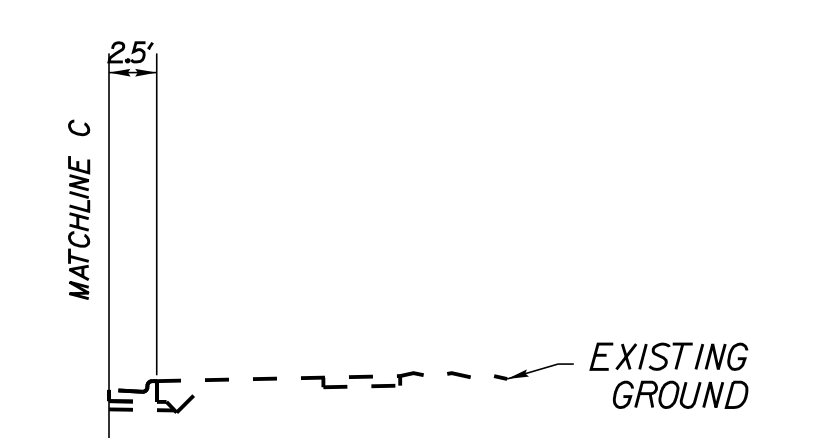

TYPICAL SECTION NO. 2D
-Y1- STA 10+72.00 TO STA 11+25.00

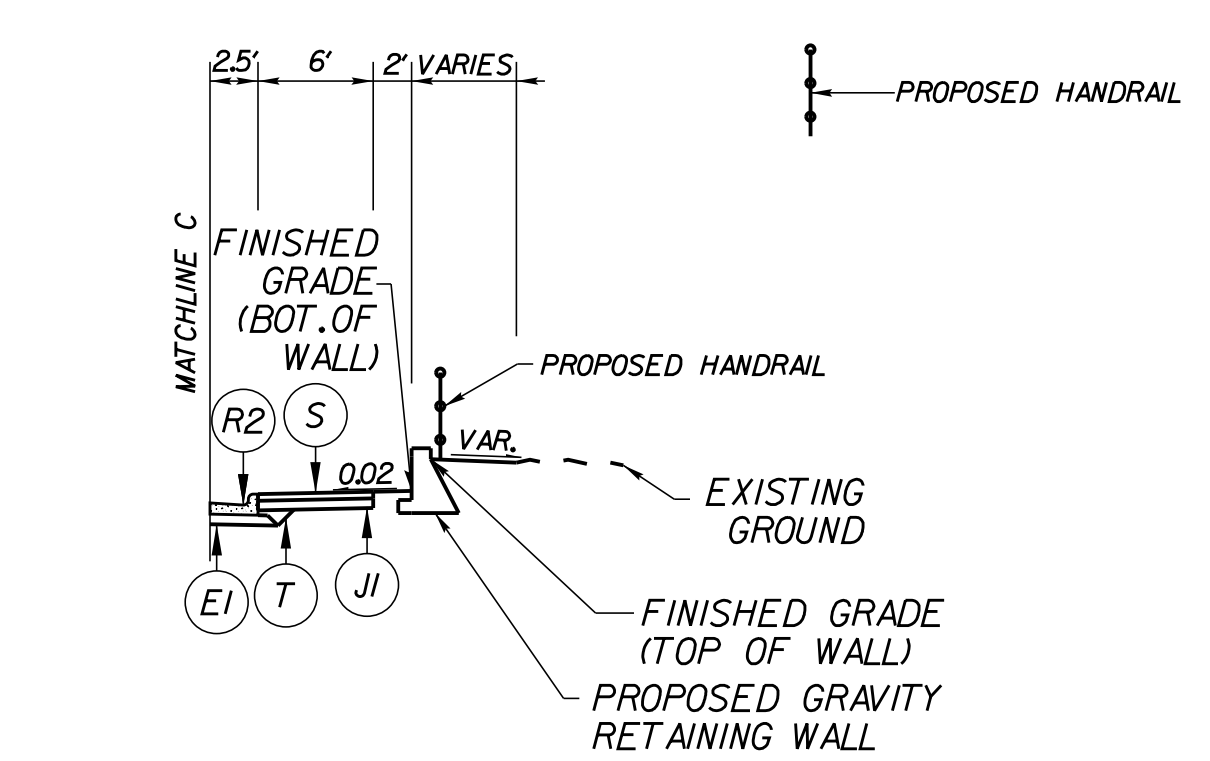

TYPICAL SECTION NO. 2E
-Y1- STA 13+75.00 TO STA 14+70.00

4. Town Certification. This design has been reviewed by the Engineer for the Town of Knightdale, and to the best of my knowledge and belief, it conforms to the requirements established in the Standard Specifications of the Town of Knightdale.
By: _____ Date: _____
Town Engineer
These plans are approved by the Town of Knightdale and serve as construction plans for this project.
By: _____ Date: _____
Administrator

NO.	REVISIONS	DATE	BY

Kimley»Horn
© 2021
300 MORRIS STREET, SUITE 200, DURHAM, NC, 27701
PHONE: 919-682-3583
WWW.KIMLEY-HORN.COM
NC LICENSE # F-0102

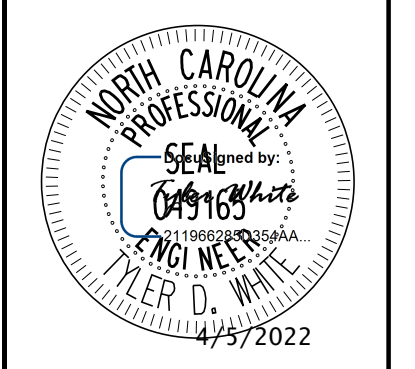

KHA PROJECT	013936008
DATE	4/4/2022
SCALE	N/T
DESIGNED BY:	TDW
DRAWN BY:	LCK
CHECKED BY:	TDW

TYPICAL SECTIONS

**MERRITT HINTON OAKS
BLVD OFFSITE
IMPROVEMENTS**
NORTH CAROLINA
KNIGHTDALE

SHEET NUMBER
R1.00

K:\DUR_Roadway\013936008 - Midway Business Park\Plan\Plan Sheets\013936008.txdgm
4/4/2022

K:\DUR_Roadway\013936008 - Midway Business Park\Plan\Plan Sheets\013936008.txd

4/4/2022

DECORATIVE STREET PRINT TYPE 'A'
 PRODUCT: TRAFFICPATTERNSXD
 BY ENNIS-FLINT
 PATTERN: HERRINGBONE
 COLOR: COLONIAL BRICK

DECORATIVE STREET PRINT TYPE 'B'
 PRODUCT: TRAFFICPATTERNSXD
 BY ENNIS-FLINT
 PATTERN: SINGLE SOLDIER COURSE
 COLOR: COLONIAL BRICK

NOTE: CONTRACTOR SHALL CONSTRUCT
 6'X6' MOCK-UP WITH PATTERN AND COLOR
 REPRESENTING FINAL FINISH FOR REVIEW
 AND APPROVAL BY PROJECT LANDSCAPE
 ARCHITECT OF EACH TYPE OF DECORATIVE
 STREET PRINT.

NOTE: HERRINGBONE PATTERN
 SHALL BE LAID ON 45° BIAS.

FINISHED POST PRINT DEPTH 10 mm
 - PATTERN AS SPECIFIED

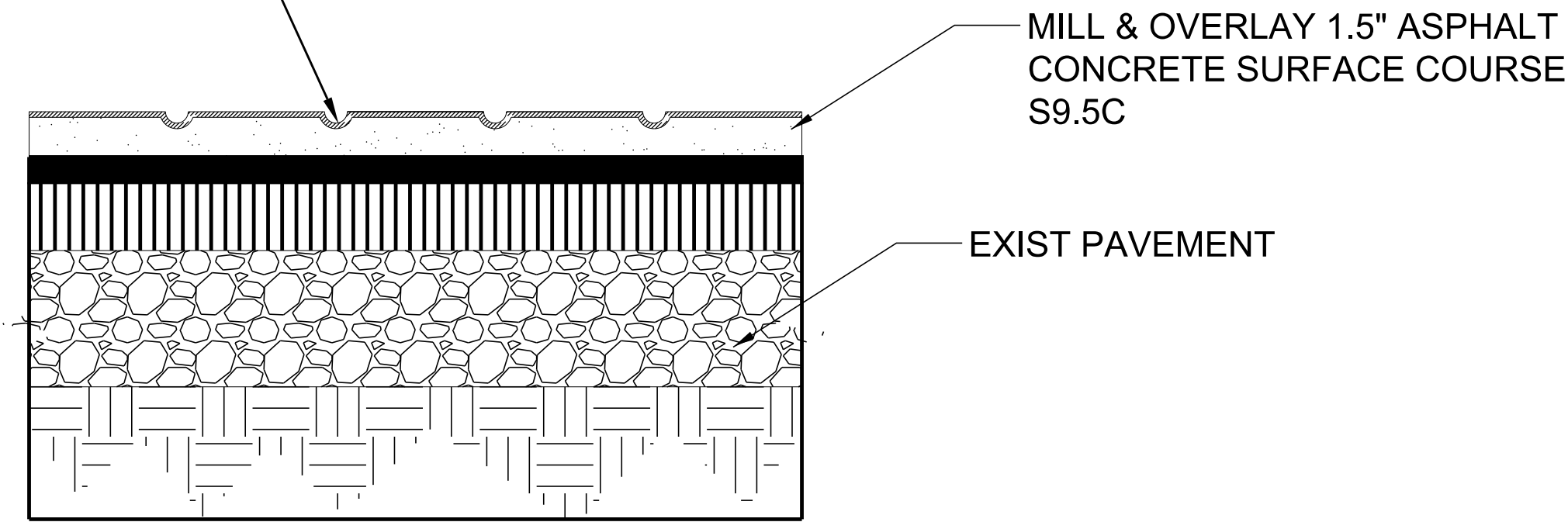

SECTION
 NOT TO SCALE

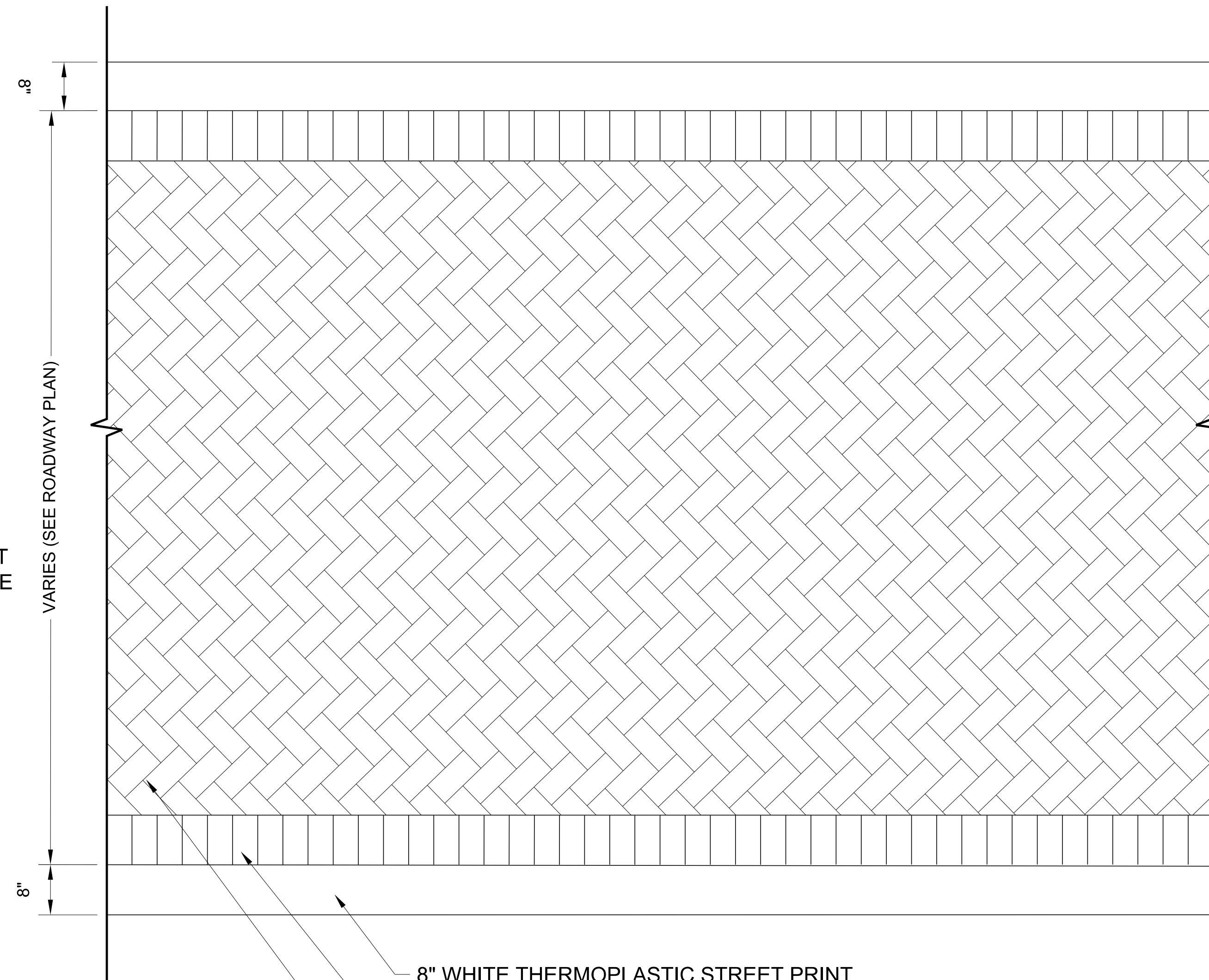

PLAN VIEW
 NOT TO SCALE

4. Town Certification. This design has been reviewed by the Engineer for the Town of Knightdale, and to the best of my knowledge and belief, it conforms to the requirements established in the Standard Specifications of the Town of Knightdale.
 By: _____ Date: _____
 Town Engineer
 These plans are approved by the Town of Knightdale and serve as construction plans for this project.
 By: _____ Date: _____
 Administrator

No.	REVISIONS	DATE	BY

Kimley»Horn
 © 2021
 300 MORRIS STREET, SUITE 200, DURHAM, NC, 27701
 PHONE: 919-682-3583
 WWW.KIMLEY-HORN.COM
 NC LICENSE #: F-0102

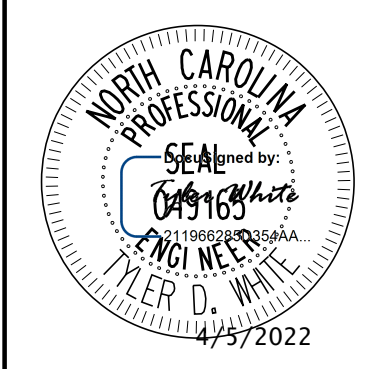

KHA PROJECT	013936008
DATE	4/4/2022
SCALE	1" = 40'
DESIGNED BY:	TOW
DRAWN BY:	LCK
CHECKED BY:	TOW

**STAMPED ASPHALT
 CROSSWALK DETAIL**

**MERRITT HINTON OAKS
 BLVD OFFSITE
 IMPROVEMENTS**
 NORTH CAROLINA
 KNIGHTDALE

SHEET NUMBER
R1.01

STATE OF NORTH CAROLINA
DEPT. OF TRANSPORTATION
DIVISION OF HIGHWAYS
RALEIGH, N.C.

ENGLISH DETAIL DRAWING FOR
**MINIMUM DEPTH
CONCRETE CATCH BASIN**
12" THRU 84" PIPE

SHEET 1 OF 2
840D02

GENERAL NOTES:
USE CLASS "B" CONCRETE THROUGHOUT.
PROVIDE ALL CATCH BASINS OVER 3'-6" IN DEPTH WITH STEPS 12" ON CENTER. USE STEPS WHICH COMPLY WITH STD. DRAWING 840.66.
OPTIONAL CONSTRUCTION - MONOLITHIC POUR, 2" KEYS, OR #4 BAR DOWELS AT 12" CENTERS AS DIRECTED BY THE ENGINEER.
USE FORMS FOR THE CONSTRUCTION OF THE BOTTOM SLAB.
IF REINFORCED CONCRETE PIPE IS SET IN BOTTOM SLAB OF BOX, ADD TO SLAB AS SHOWN ON STD. NO. 840.00.
USE TYPE "E", "F" AND "G" GRATES UNLESS OTHERWISE INDICATED.
FOR 8'-0" IN HEIGHT OR LESS USE 6" WALLS AND BOTTOM SLAB. OVER 8'-0" TO 16'-0" IN HEIGHT USE 8" WALLS AND BOTTOM SLAB. ADJUST QUANTITIES ACCORDINGLY.
CONSTRUCT WITH PIPE CROWNS MATCHING.
CHAMFER ALL EXPOSED CORNERS 1".
** FOR STRUCTURES WITH PIPE LARGER THAN 54", MAKE THE TOP SLAB 8" THICK.

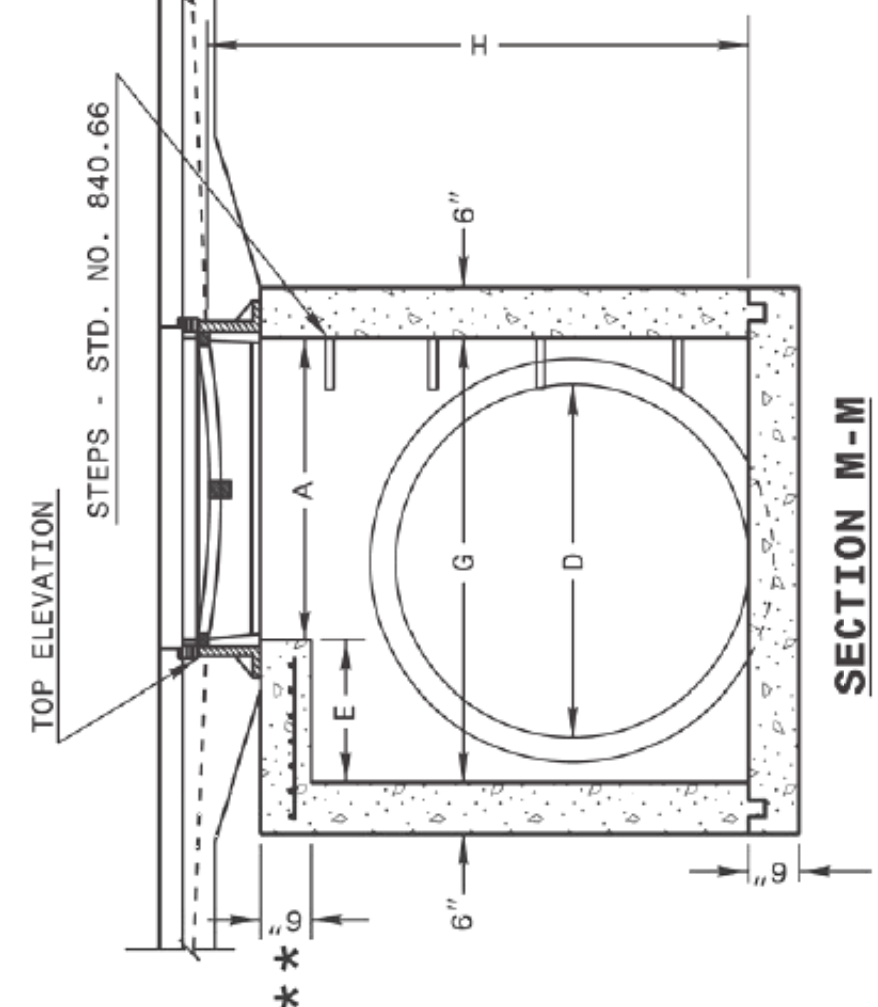
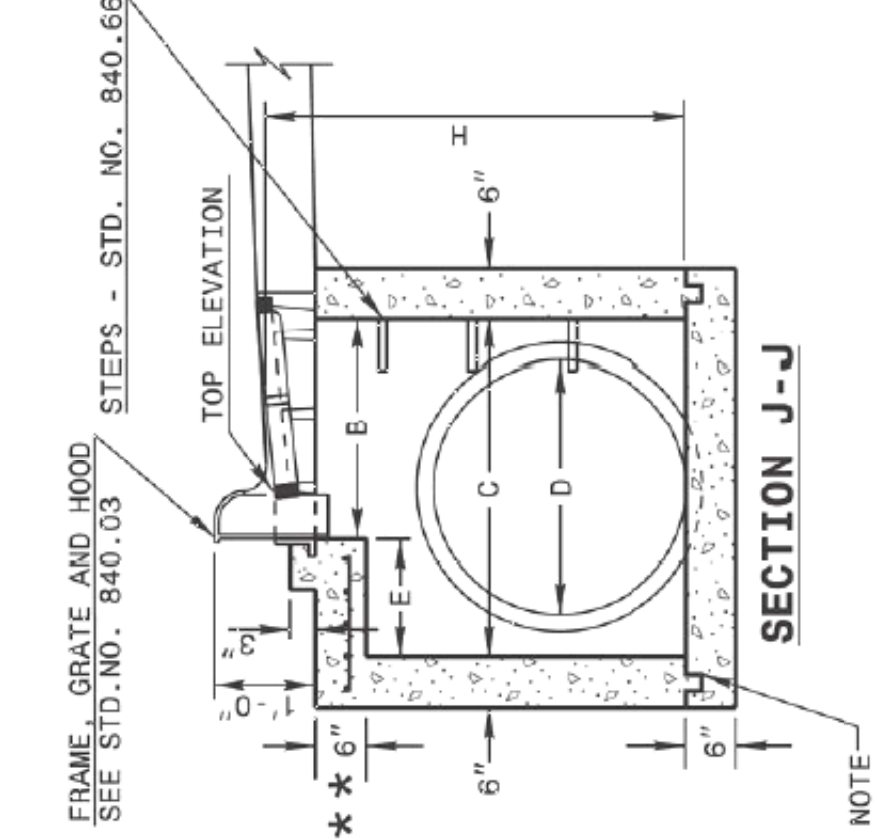
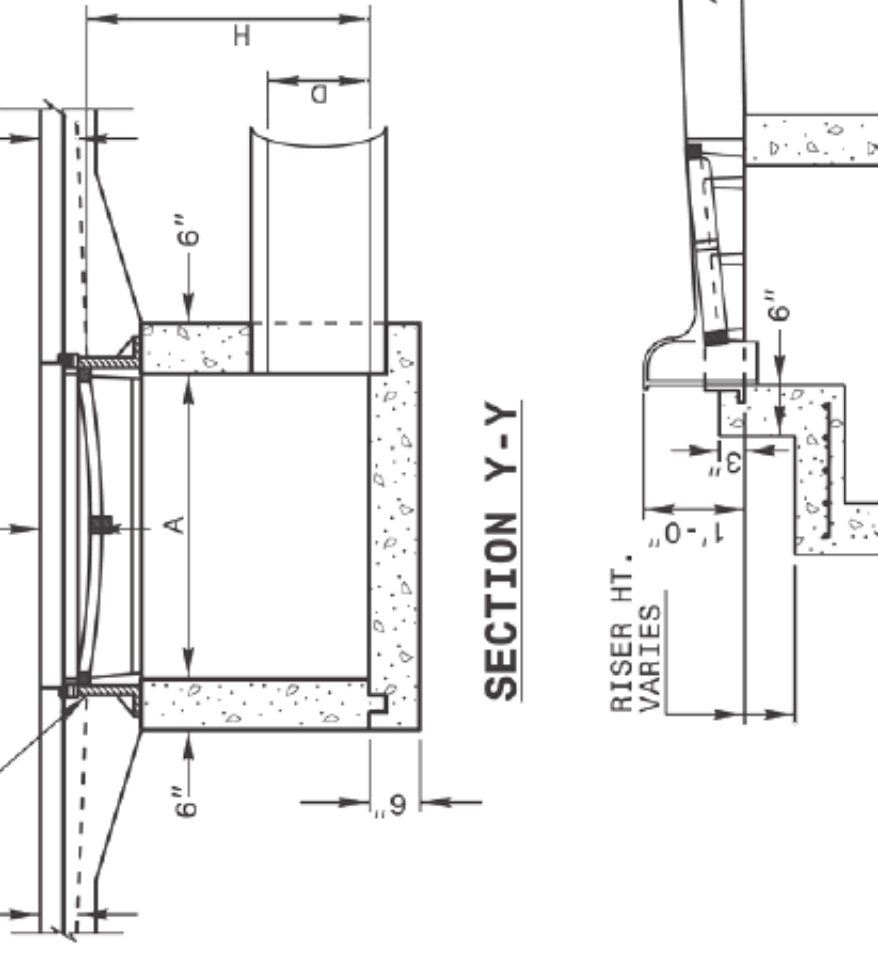
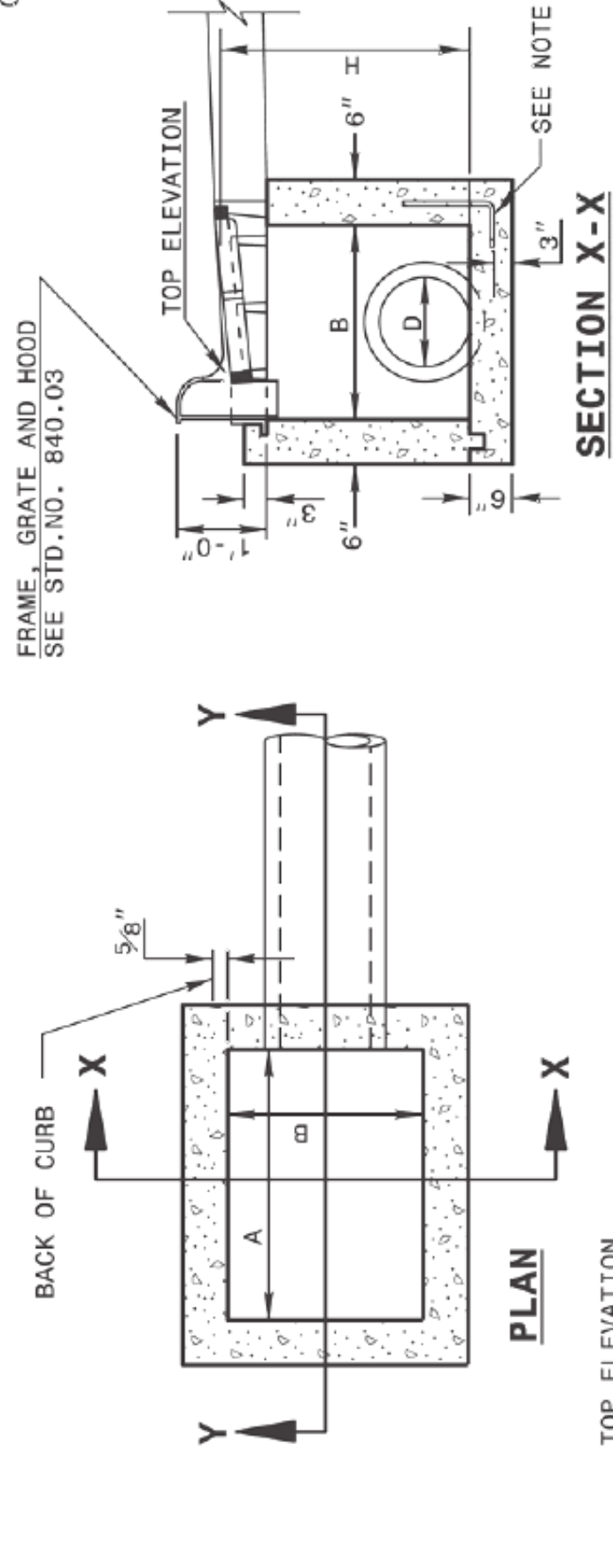

STATE OF NORTH CAROLINA
DEPT. OF TRANSPORTATION
DIVISION OF HIGHWAYS
RALEIGH, N.C.

ENGLISH DETAIL DRAWING FOR
**MINIMUM DEPTH
CONCRETE CATCH BASIN**
12" THRU 84" PIPE

SHEET 1 OF 2
840D02

STATE OF NORTH CAROLINA
DEPT. OF TRANSPORTATION
DIVISION OF HIGHWAYS
RALEIGH, N.C.

ENGLISH DETAIL DRAWING FOR
**MINIMUM DEPTH
CONCRETE CATCH BASIN**
12" THRU 84" PIPE

SHEET 2 OF 2
840D02

** FOR STRUCTURES WITH PIPE LARGER THAN 54", MAKE THE TOP SLAB 8" THICK.

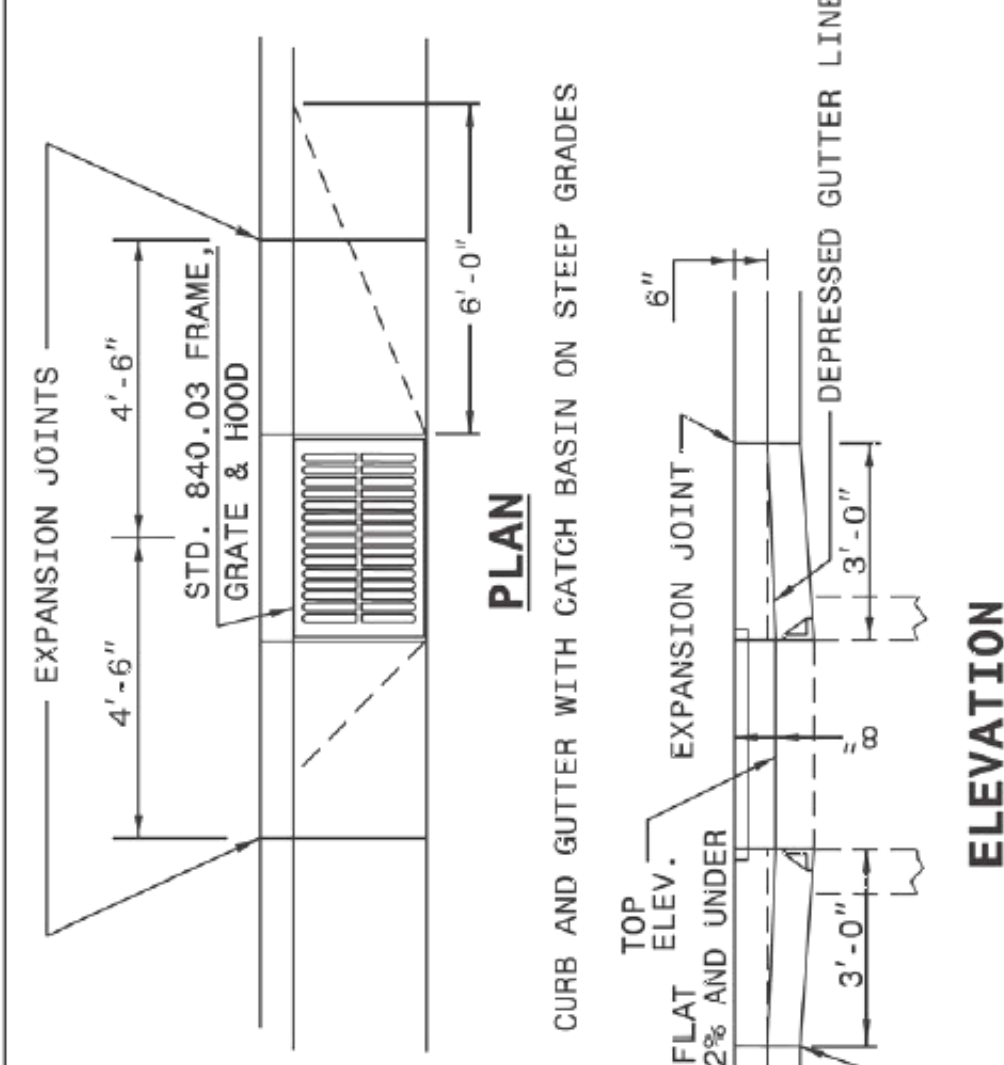

SECTION S-S

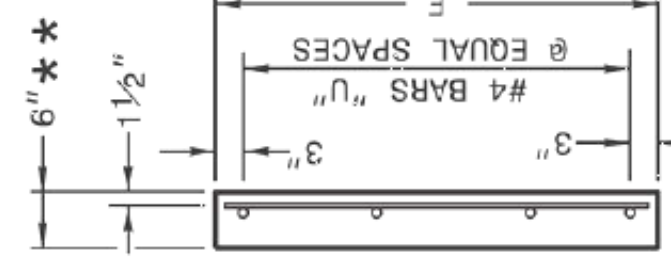

DOWEL

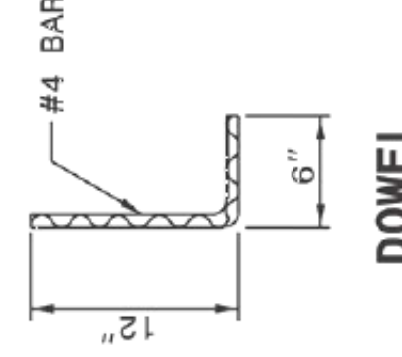

PLAN OF TOP SLAB

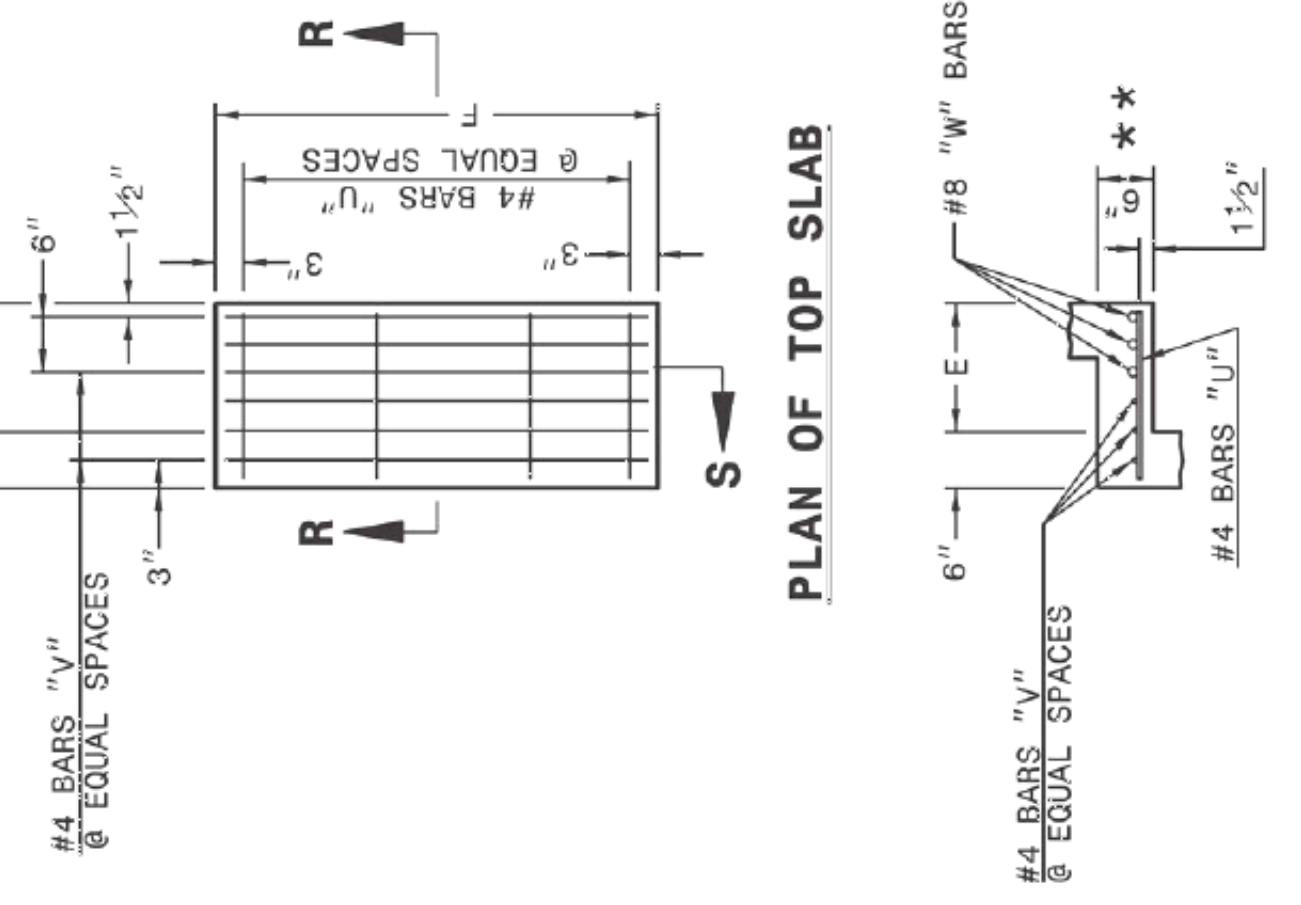

SECTION R-R

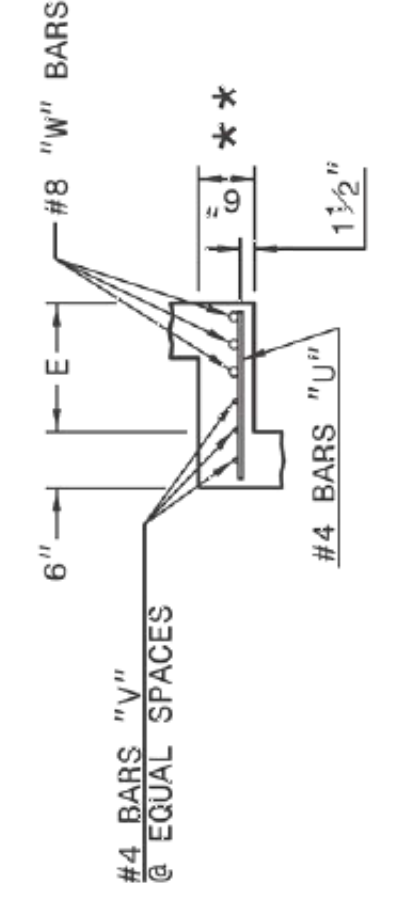

* RISER HAS .228 CUBIC YARDS OF CONCRETE PER FOOT HEIGHT

PIPE D	DIMENSIONS OF BOX AND PIPE			COVER DIMENSION			BARS-U			BARS-V			BARS-W			TOTAL LBS.	DEDUCTIONS FOR MINIMUM HEIGHT, H	C.M.	R.C.		
	SPAN	WIDTH	DEPTH	E	F	G	NO.	LENGTH	NO.	LENGTH	NO.	LENGTH	NO.	LENGTH	TOP SLAB					BOTTOM SLAB	ONE PIPE
12	3'-0"	2'-2"	2'-0"	2'-0"	2'-0"	2'-0"	2'-0"	2'-0"	2'-0"	2'-0"	2'-0"	2'-0"	2'-0"	2'-0"	2'-0"	2'-0"	0.235	0.772	0.015	0.026	
15	3'-0"	2'-2"	2'-3"	2'-3"	2'-3"	2'-3"	2'-3"	2'-3"	2'-3"	2'-3"	2'-3"	2'-3"	2'-3"	2'-3"	2'-3"	2'-3"	0.235	0.887	0.033	0.049	
18	3'-0"	2'-2"	2'-6"	2'-6"	2'-6"	2'-6"	2'-6"	2'-6"	2'-6"	2'-6"	2'-6"	2'-6"	2'-6"	2'-6"	2'-6"	2'-6"	0.235	0.859	0.033	0.049	
24	3'-0"	2'-2"	3'-1"	3'-1"	3'-1"	3'-1"	3'-1"	3'-1"	3'-1"	3'-1"	3'-1"	3'-1"	3'-1"	3'-1"	3'-1"	3'-1"	0.235	1.001	0.059	0.085	
30	3'-0"	2'-2"	3'-4"	3'-4"	3'-4"	3'-4"	3'-4"	3'-4"	3'-4"	3'-4"	3'-4"	3'-4"	3'-4"	3'-4"	3'-4"	3'-4"	0.123	0.347	1.433	0.092	0.127
36	3'-0"	2'-2"	3'-10"	3'-10"	3'-10"	3'-10"	3'-10"	3'-10"	3'-10"	3'-10"	3'-10"	3'-10"	3'-10"	3'-10"	3'-10"	3'-10"	0.161	0.432	1.714	0.132	0.178
42	3'-0"	2'-2"	4'-5"	4'-5"	4'-5"	4'-5"	4'-5"	4'-5"	4'-5"	4'-5"	4'-5"	4'-5"	4'-5"	4'-5"	4'-5"	4'-5"	0.200	0.543	1.758	0.180	0.243
48	3'-0"	2'-2"	5'-0"	5'-0"	5'-0"	5'-0"	5'-0"	5'-0"	5'-0"	5'-0"	5'-0"	5'-0"	5'-0"	5'-0"	5'-0"	5'-0"	0.235	0.667	2.052	0.235	0.317
54	3'-0"	2'-2"	5'-7"	5'-7"	5'-7"	5'-7"	5'-7"	5'-7"	5'-7"	5'-7"	5'-7"	5'-7"	5'-7"	5'-7"	5'-7"	5'-7"	0.289	0.802	2.387	0.287	0.401
60	3'-0"	2'-2"	6'-3"	6'-3"	6'-3"	6'-3"	6'-3"	6'-3"	6'-3"	6'-3"	6'-3"	6'-3"	6'-3"	6'-3"	6'-3"	6'-3"	0.340	0.973	2.722	0.340	0.468
66	3'-0"	2'-2"	6'-11"	6'-11"	6'-11"	6'-11"	6'-11"	6'-11"	6'-11"	6'-11"	6'-11"	6'-11"	6'-11"	6'-11"	6'-11"	6'-11"	0.391	1.160	3.057	0.440	0.555
72	3'-0"	2'-2"	7'-6"	7'-6"	7'-6"	7'-6"	7'-6"	7'-6"	7'-6"	7'-6"	7'-6"	7'-6"	7'-6"	7'-6"	7'-6"	7'-6"	0.442	1.340	3.392	0.524	0.774
78	3'-0"	2'-2"	8'-1"	8'-1"	8'-1"	8'-1"	8'-1"	8'-1"	8'-1"	8'-1"	8'-1"	8'-1"	8'-1"	8'-1"	8'-1"	8'-1"	0.493	1.530	3.727	0.615	0.893
84	3'-0"	2'-2"	8'-9"	8'-9"	8'-9"	8'-9"	8'-9"	8'-9"	8'-9"	8'-9"	8'-9"	8'-9"	8'-9"	8'-9"	8'-9"	8'-9"	0.544	1.760	4.062	0.713	1.010

STATE OF NORTH CAROLINA
DEPT. OF TRANSPORTATION
DIVISION OF HIGHWAYS
RALEIGH, N.C.

ENGLISH DETAIL DRAWING FOR
**MINIMUM DEPTH
CONCRETE CATCH BASIN**
12" THRU 84" PIPE

SHEET 2 OF 2
840D02

4. Town Certification. This design has been reviewed by the Engineer for the Town of Knightdale, and to the best of my knowledge and belief, it conforms to the requirements established in the Standard Specifications of the Town of Knightdale.
By: _____ Date: _____
Town Engineer
These plans are prepared by the Town of Knightdale and serve as construction plans for its project.
By: _____ Date: _____
Administrator

MERRITT HINTON OAKS
BLVD OFFSITE
IMPROVEMENTS

SHEET NUMBER
R1.02

DRAINAGE DETAILS

KHA PROJECT
013936008
DATE
4/4/2022
SCALE
1"=40'
DESIGNED BY: TDW
DRAWN BY: LCK
CHECKED BY: TDW

Kimley»Horn

© 2021
300 MORRIS STREET, SUITE 200, DURHAM, NC, 27701
PHONE: 919-682-3583
WWW.KIMLEY-HORN.COM
NC LICENSE # F-1012

NO. _____ REVISIONS _____ BY _____ DATE _____

K:\DUR_Roadway\013936008 - Midway Business Park\Plan\Plan Sheets\013936008_wall_pr1_DT.Ldgn

4/4/2022

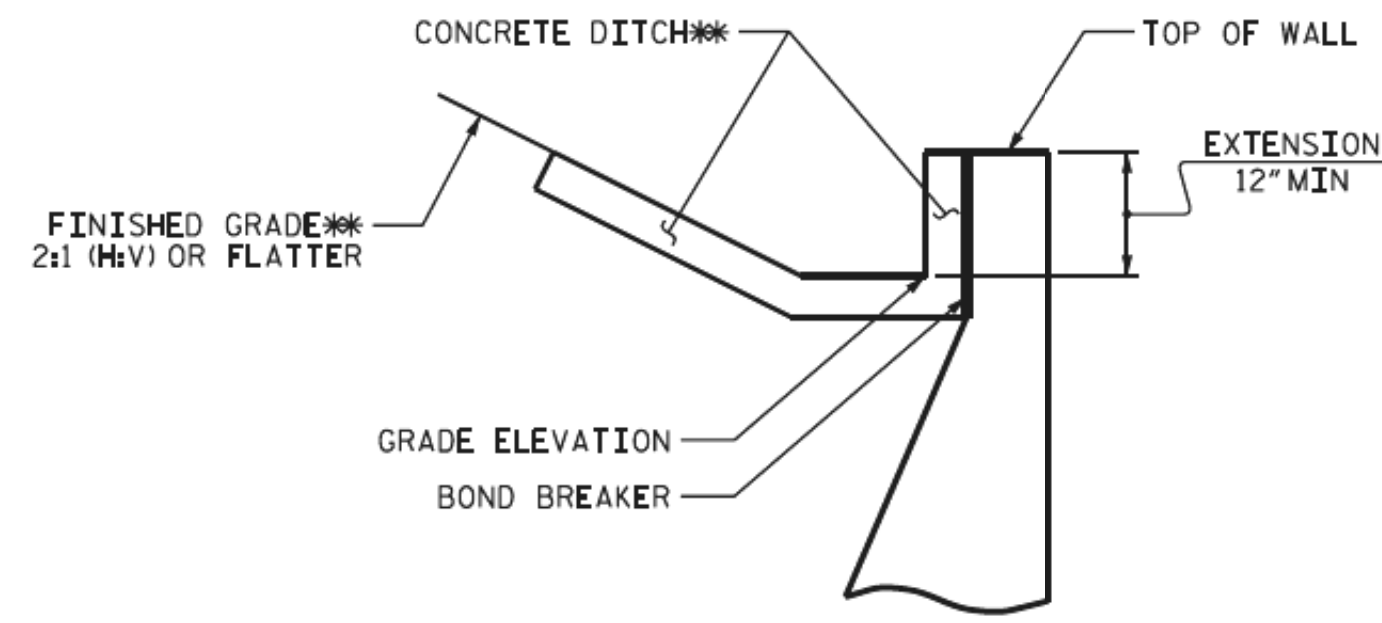
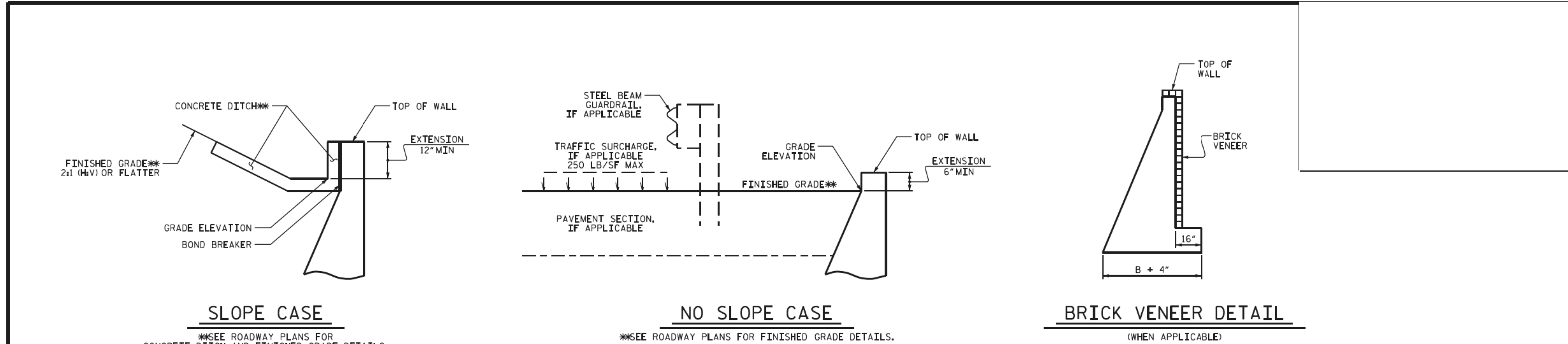

SLOPE CASE
**SEE ROADWAY PLANS FOR CONCRETE DITCH AND FINISHED GRADE DETAILS.

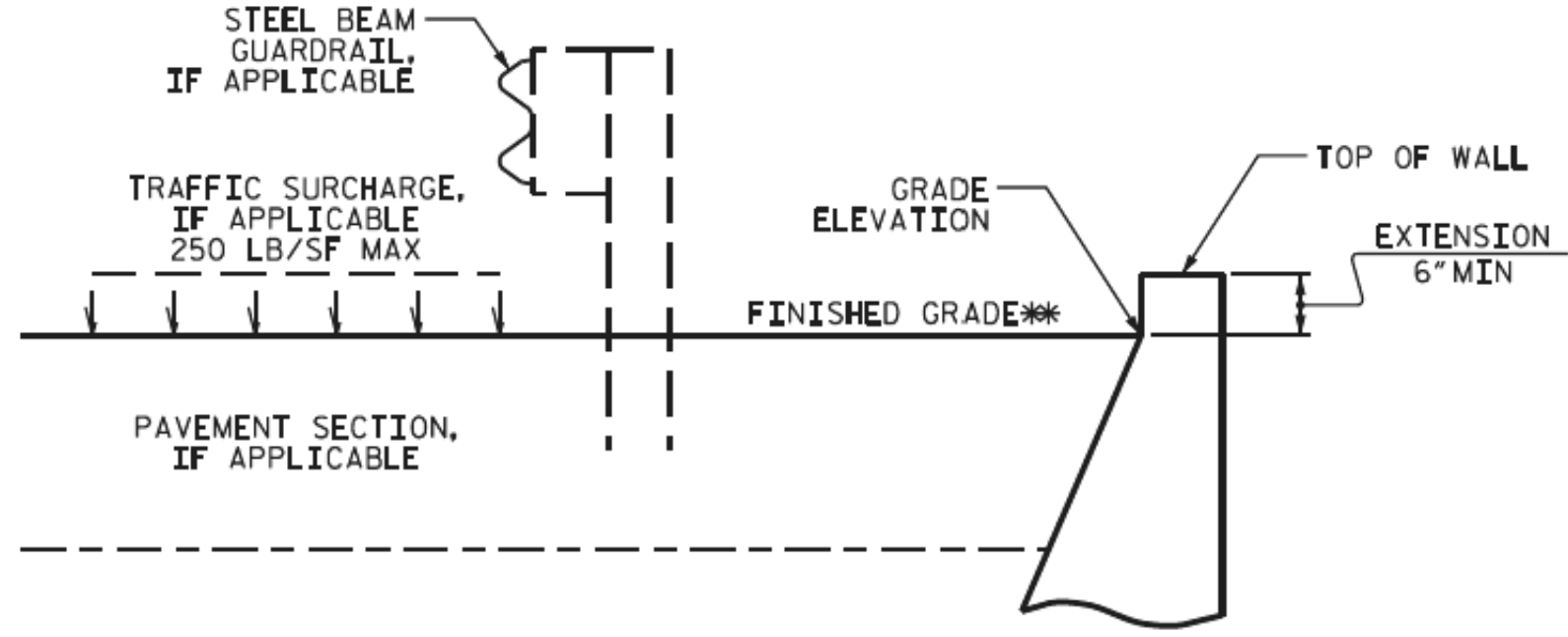

NO SLOPE CASE
**SEE ROADWAY PLANS FOR FINISHED GRADE DETAILS.

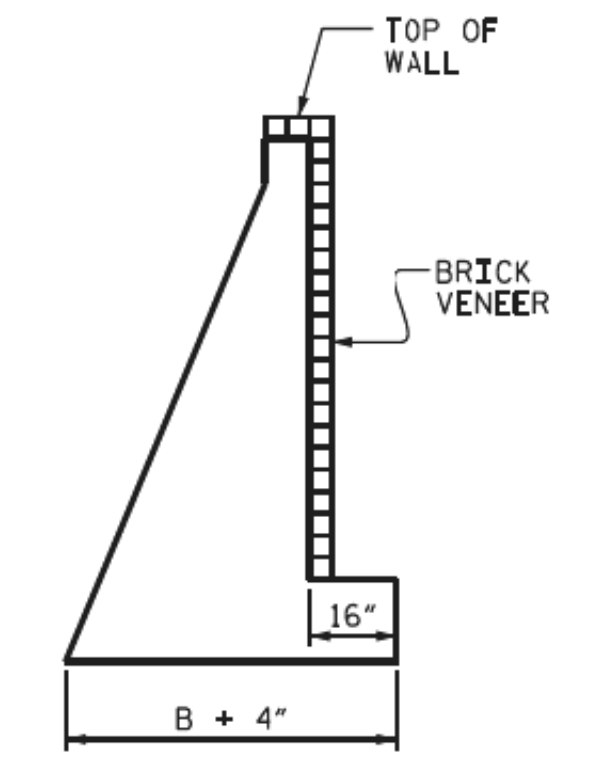

BRICK VENEER DETAIL
(WHEN APPLICABLE)

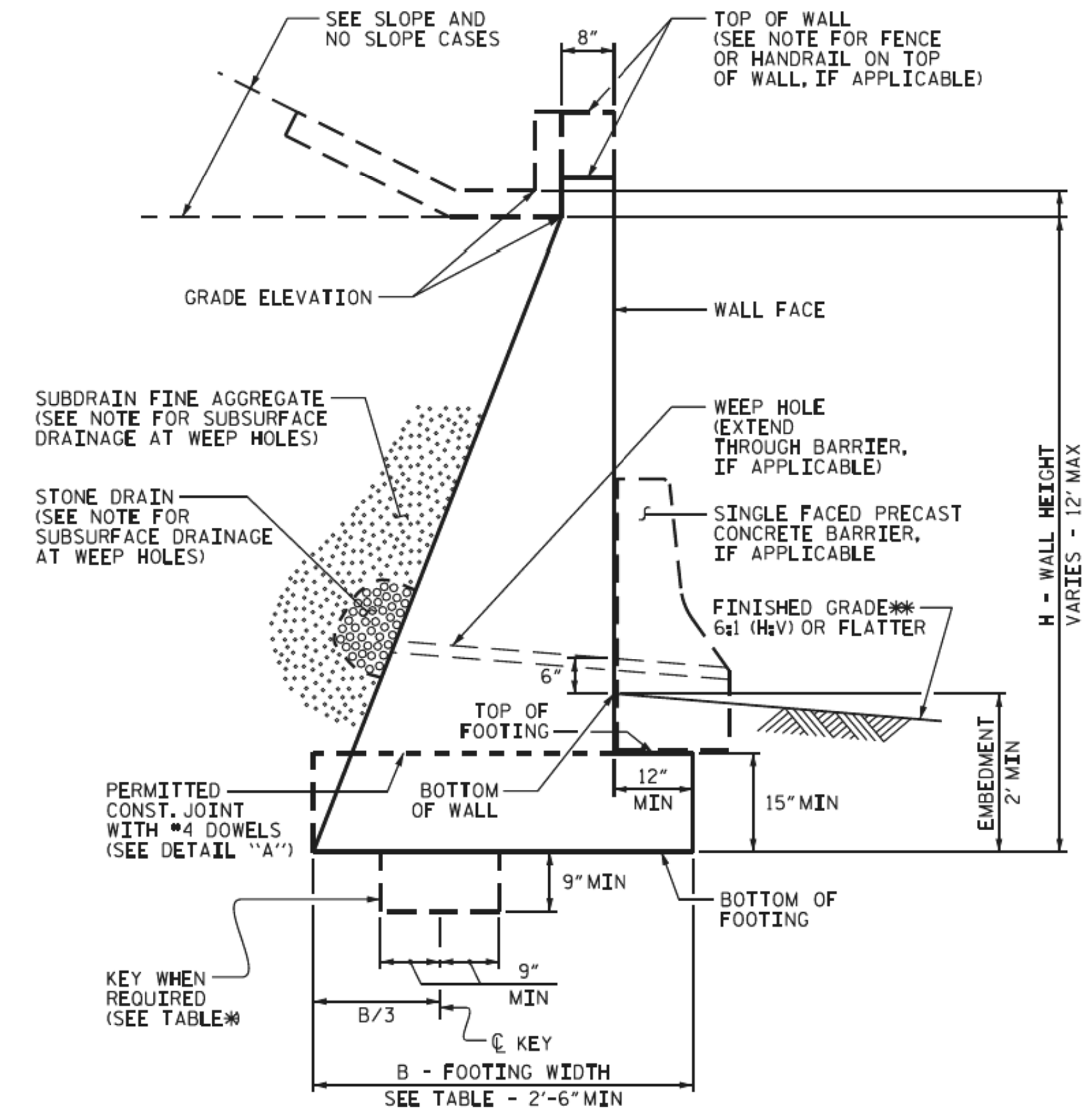

STANDARD CIP GRAVITY WALL
**SEE ROADWAY PLANS FOR FINISHED GRADE DETAILS.

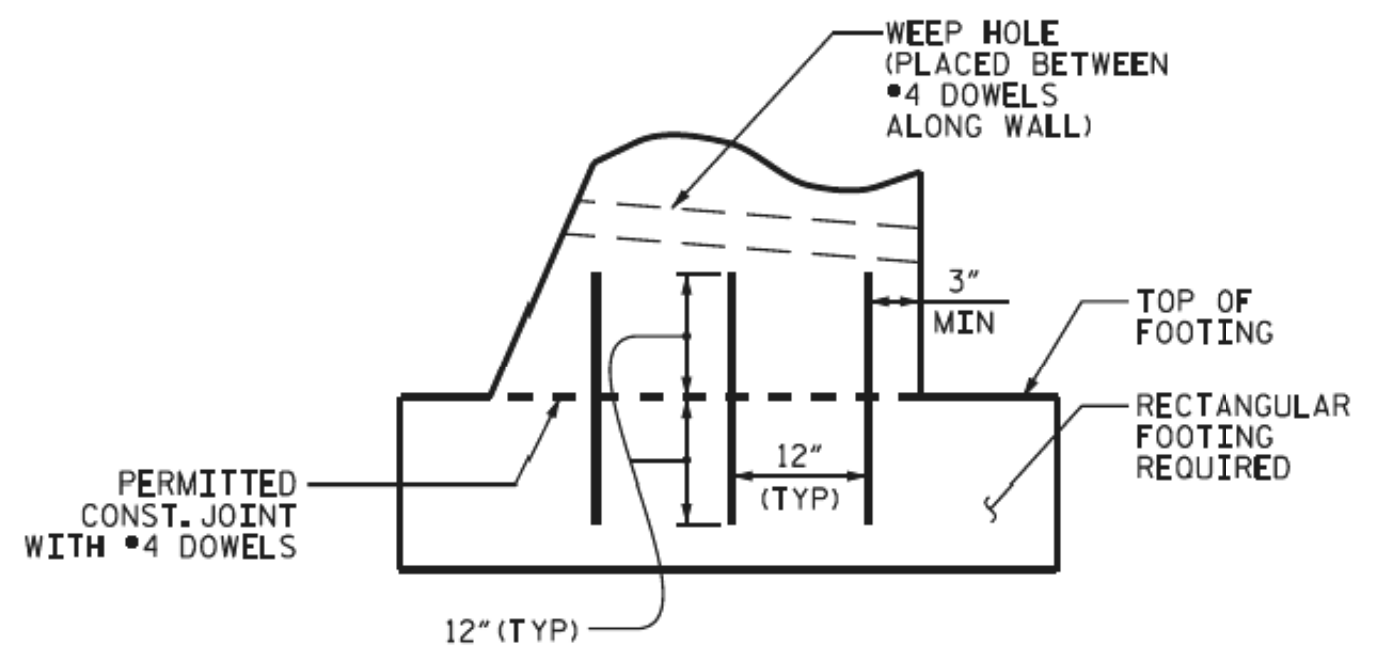

DETAIL "A"

H (FT)	3 - < 6	6 - 9	> 9 - 12
SLOPE CASE	.66	.70*	.75*
NO SLOPE CASE WITH TRAFFIC SURCHARGE	.80	.75*	.70*
NO SLOPE CASE WITHOUT TRAFFIC SURCHARGE	.60	.60	.60

B/H RATIO (B = 2'-6" MIN)
*KEY IS REQUIRED FOR "SLOPE CASE" OR "NO SLOPE CASE WITH TRAFFIC SURCHARGE" WHEN H IS 6' OR GREATER.

NOTES:

FOR STANDARD CAST-IN-PLACE (CIP) GRAVITY RETAINING WALLS, SEE CAST-IN-PLACE GRAVITY RETAINING WALLS PROVISION.

FOR STEEL BEAM GUARDRAIL, SEE ROADWAY PLANS AND SECTION 862 OF THE STANDARD SPECIFICATIONS.

FOR SINGLE FACED PRECAST CONCRETE BARRIER, SEE ROADWAY PLANS AND SECTION 857 OF THE STANDARD SPECIFICATIONS.

FOR FENCES OR HANDRAILS ON TOP OF WALLS, SEE ROADWAY PLANS FOR FENCE OR HANDRAIL ATTACHMENT DETAILS.

FOR SUBSURFACE DRAINAGE AT WEEP HOLES, SEE ARTICLE 414-8 OF THE STANDARD SPECIFICATIONS.

STANDARD CIP GRAVITY WALLS ARE BASED ON THE FOLLOWING IN-SITU ASSUMED SOIL PARAMETERS:
 UNIT WEIGHT, $\gamma = 120$ LB/CF
 FRICTION ANGLE, $\phi = 35$ DEGREES (GROUNDWATER WITHIN 7' OF BOTTOM OF FOOTING)
 FRICTION ANGLE, $\phi = 30$ DEGREES (GROUNDWATER MORE THAN 7' BELOW BOTTOM OF FOOTING)
 COHESION, $c = 0$ LB/SF

DO NOT USE STANDARD CIP GRAVITY WALLS IF ASSUMED SOIL PARAMETERS ARE NOT APPLICABLE OR GROUNDWATER IS ABOVE BOTTOM OF FOOTING.

DO NOT USE STANDARD CIP GRAVITY WALLS WHEN VERY LOOSE OR SOFT SOIL OR MUCK IS BELOW WALLS.

BEFORE BEGINNING STANDARD CIP GRAVITY WALL CONSTRUCTION, SURVEY WALL LOCATIONS AND SUBMIT WALL PROFILE VIEWS (WALL ENVELOPES) FOR REVIEW. FOR WALL ENVELOPES, INCLUDE BOTTOM OF WALL, EXISTING GROUND AND GRADE ELEVATIONS AND OTHER ELEVATIONS AS NEEDED AT INTERVALS OF 25' OR LESS ALONG WALLS. DO NOT START WALL CONSTRUCTION UNTIL WALL ENVELOPES ARE ACCEPTED.

FOR BRICK VENEERS, SUBMIT BRICK SAMPLES FOR APPROVAL BEFORE BEGINNING STANDARD CIP GRAVITY WALL CONSTRUCTION.

DO NOT PLACE CONCRETE FOR FOOTINGS UNTIL EXCAVATION DIMENSIONS AND FOUNDATION MATERIAL ARE APPROVED.

WHEN CONSTRUCTING STANDARD CIP GRAVITY WALLS WITH A CONSTRUCTION JOINT AS SHOWN IN DETAIL "A", PROVIDE A MINIMUM OF 3 EQUALLY SPACED *4 DOWELS AT INTERVALS OF 1'-6" ALONG WALLS.



NORTH CAROLINA
DEPARTMENT OF TRANSPORTATION
DIVISION OF HIGHWAYS

GEOTECHNICAL
ENGINEERING UNIT

STANDARD DETAIL NO. 453.01

STANDARD
CAST-IN-PLACE (CIP)
GRAVITY RETAINING WALL

DATE: 5-16-17

By: _____ Date: _____
 Town Engineer

By: _____ Date: _____
 Administration

MERRITT HINTON OAKS
BLVD OFFSITE
IMPROVEMENTS

NORTH CAROLINA
KNIGHTDALE

GRAVITY RETAINING
WALL NOTES &
DETAILS

REVISIONS

No.	By	Date

013936008
DATE
4/4/2022

SCALE 1" = 40'
DESIGNED BY: TDW
DRAWN BY: LCK
CHECKED BY: TDW

© 2021
300 MORRIS STREET, SUITE 200, DURHAM, NC, 27701
PHONE: 919-682-3583
WWW.KIMLEY-HORN.COM
NC LICENSE # F-0102

Kimley»Horn

SHEET NUMBER
R1.06

K:\DUR_Roadway\013936008 - Midway Business Park\Plan\Plan Sheets\013936008_EC_psh_4.dgn

4/4/2022

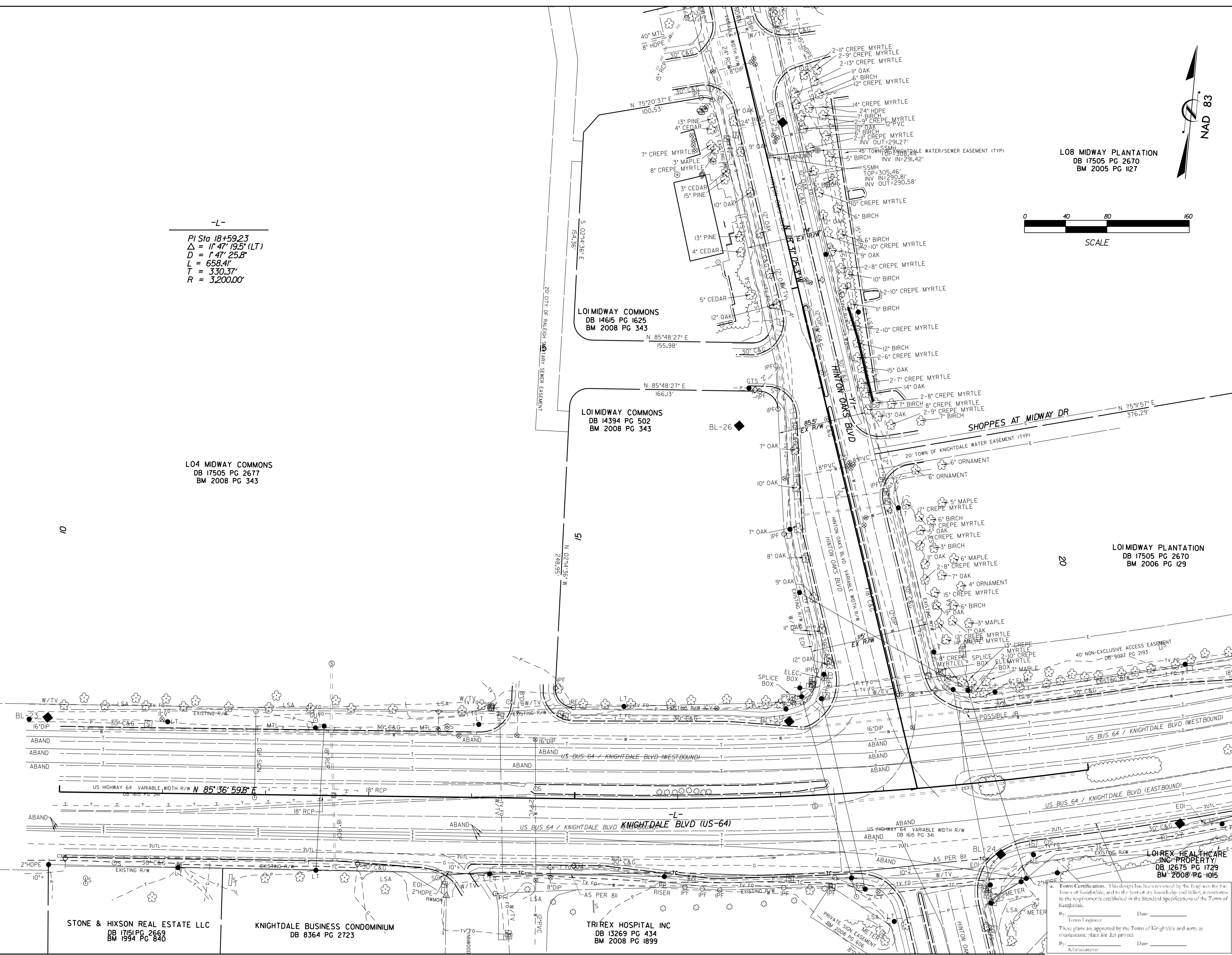

-L-

PI Sta 18+59.23
 $\Delta = 1' 47' 19.5'' (LT)$
 $D = 1' 47' 25.8''$
 $L = 658.41'$
 $T = 330.37'$
 $R = 3,200.00'$

L04 MIDWAY COMMONS
 DB 17505 PG 2677
 BM 2008 PG 343

L01 MIDWAY COMMONS
 DB 14615 PG 1625
 BM 2008 PG 343

L01 MIDWAY COMMONS
 DB 14394 PG 502
 BM 2008 PG 343

L08 MIDWAY PLANTATION
 DB 17505 PG 2670
 BM 2005 PG 1127

L01 MIDWAY PLANTATION
 DB 17505 PG 2670
 BM 2006 PG 129

L01 REX HEALTHCARE
 INC - PROPERTY
 DB 12675 PG 1729
 BM 2008 PG 1015

STONE & HIXSON REAL ESTATE LLC
 DB 17151 PG 2669
 BM 1994 PG 840

KNIGHTDALE BUSINESS CONDOMINIUM
 DB 8364 PG 2723

TRIREX HOSPITAL INC
 DB 13269 PG 434
 BM 2008 PG 1899

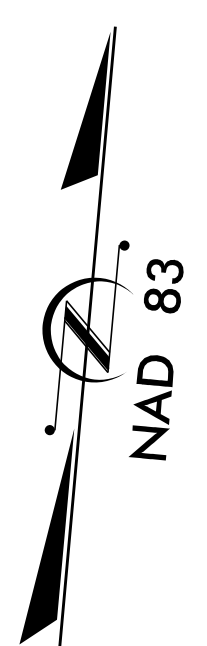
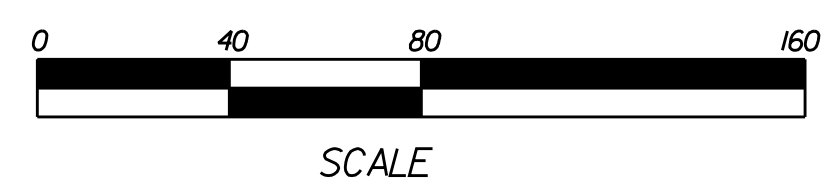

1. Town Certification. This design has been reviewed by the Engineer for the Town of Knightdale, and to the best of my knowledge and belief, it conforms to the requirements established in the Standard Specifications of the Town of Knightdale.
 By: _____ Date: _____
 Town Engineer
 These plans are approved by the Town of Knightdale and serve as construction plans for this project.
 By: _____ Date: _____
 Administrator

No.	REVISIONS	DATE	BY

Kimley»Horn

© 2021
 300 MORRIS STREET, SUITE 200, DURHAM, NC, 27701
 PHONE: 919-682-3583
 WWW.KIMLEY-HORN.COM
 NC LICENSE # F-0102

KHA PROJECT	DATE	SCALE	DESIGNED BY	DRAWN BY	CHECKED BY
013936008	4/4/2022	1"=40'	TDW	LCK	TDW

**EXISTING
 CONDITIONS**

**MERRITT HINTON OAKS
 BLVD OFFSITE
 IMPROVEMENTS**

NORTH CAROLINA
 KNIGHTDALE

SHEET NUMBER
R1.07

K:\DUR_Roadway\013936008 - Midway Business Park\Plan\Plan Sheets\013936008.plt.dgn
4/4/2022

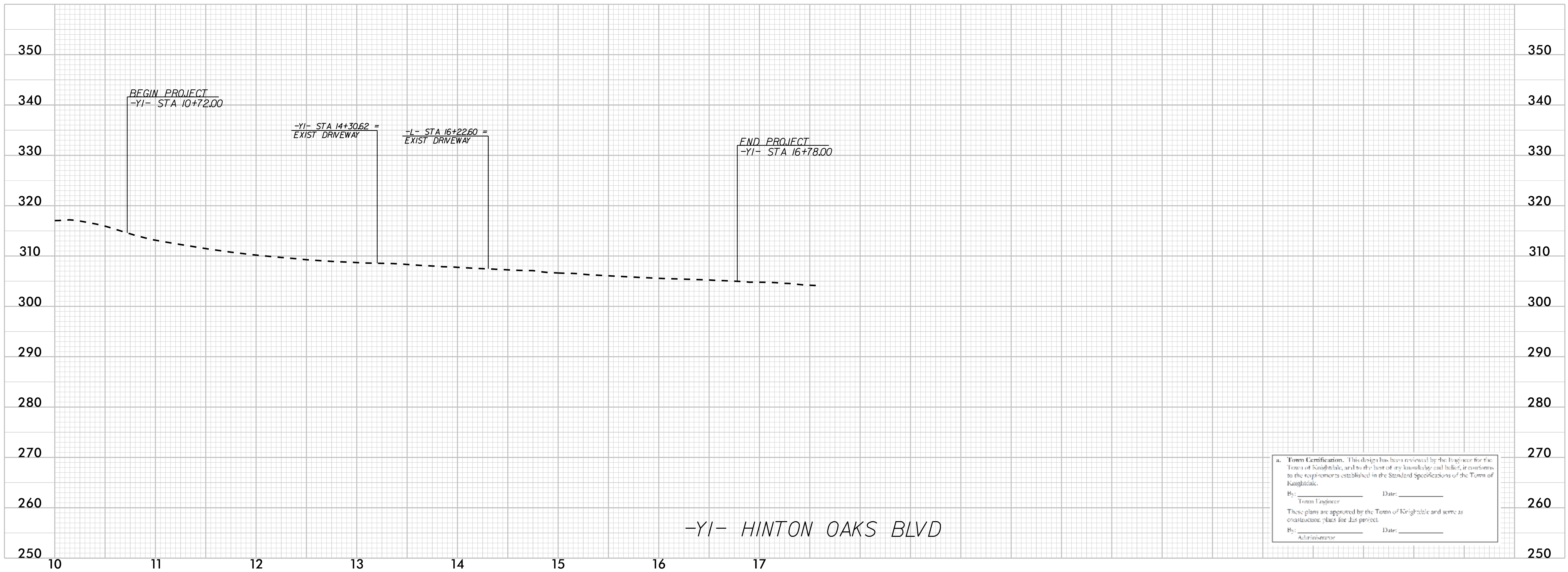
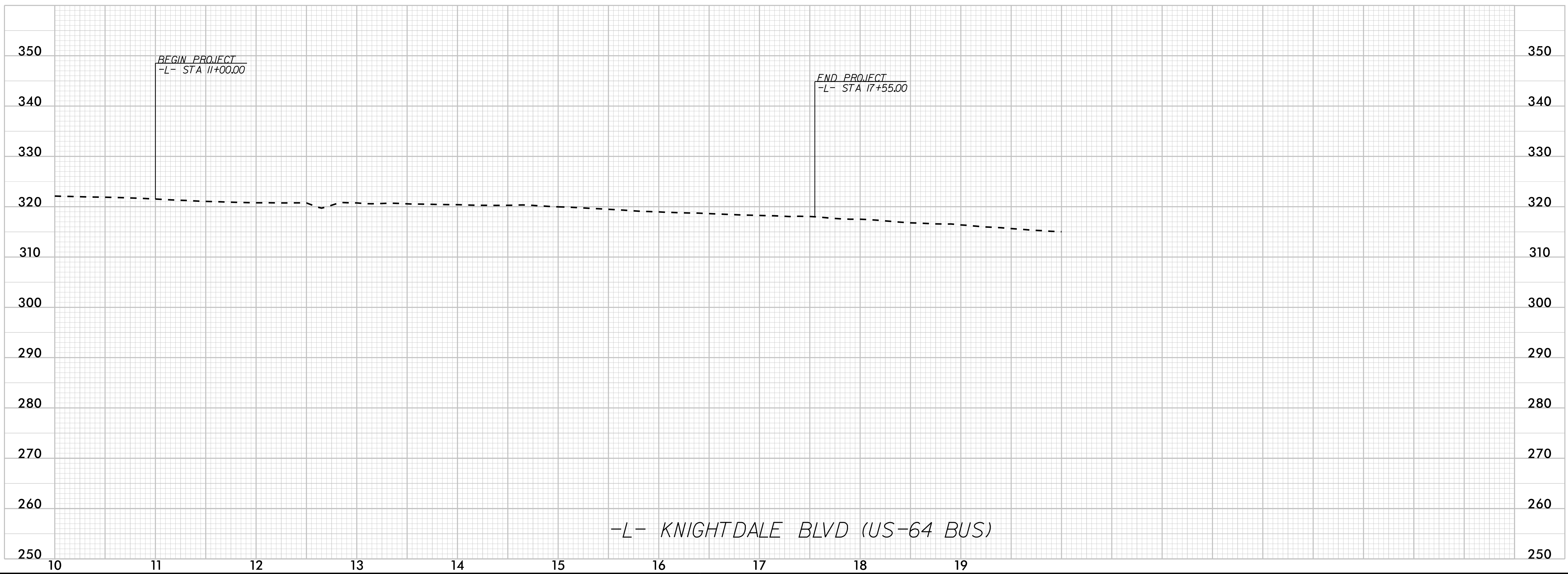

a. Town Certification. This design has been reviewed by the Engineer for the Town of Knightdale, and to the best of my knowledge and belief, it conforms to the requirements established in the Standard Specifications of the Town of Knightdale.

By: _____ Date: _____
Town Engineer

These plans are approved by the Town of Knightdale and serve as construction plans for this project.

By: _____ Date: _____
Administrator

No.	REVISIONS	DATE	BY

Kimley»Horn

© 2021
300 MORRIS STREET, SUITE 200, DURHAM, NC, 27701
PHONE: 919-682-3683
WWW.KIMLEY-HORN.COM
NC LICENSE #: F-0102

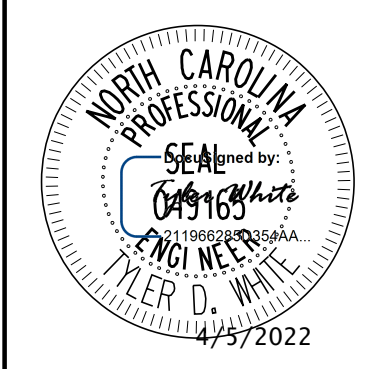

KHA PROJECT	013936008
DATE	4/4/2022
SCALE	1"=50'
DESIGNED BY:	TOW
DRAWN BY:	LCK
CHECKED BY:	TOW

PROFILE

**MERRITT HINTON OAKS
BLVD OFFSITE
IMPROVEMENTS**

NORTH CAROLINA
KNIGHTDALE

K:\DUR_Roadway\013936008 - Midway Business Park\Plan\Plan Sheets\013936008_pf1.dgn 4/4/2022

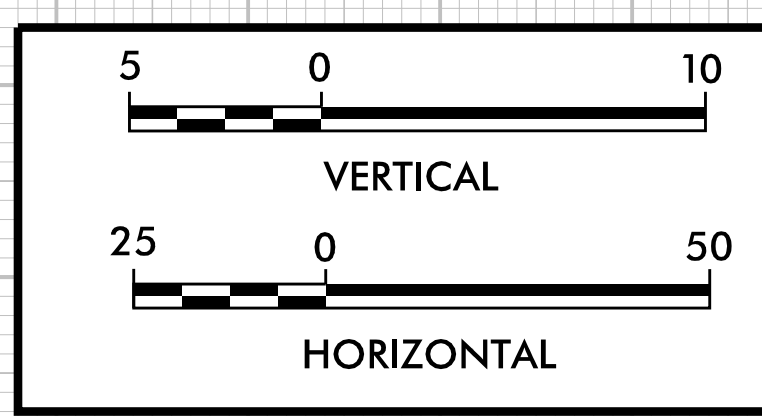
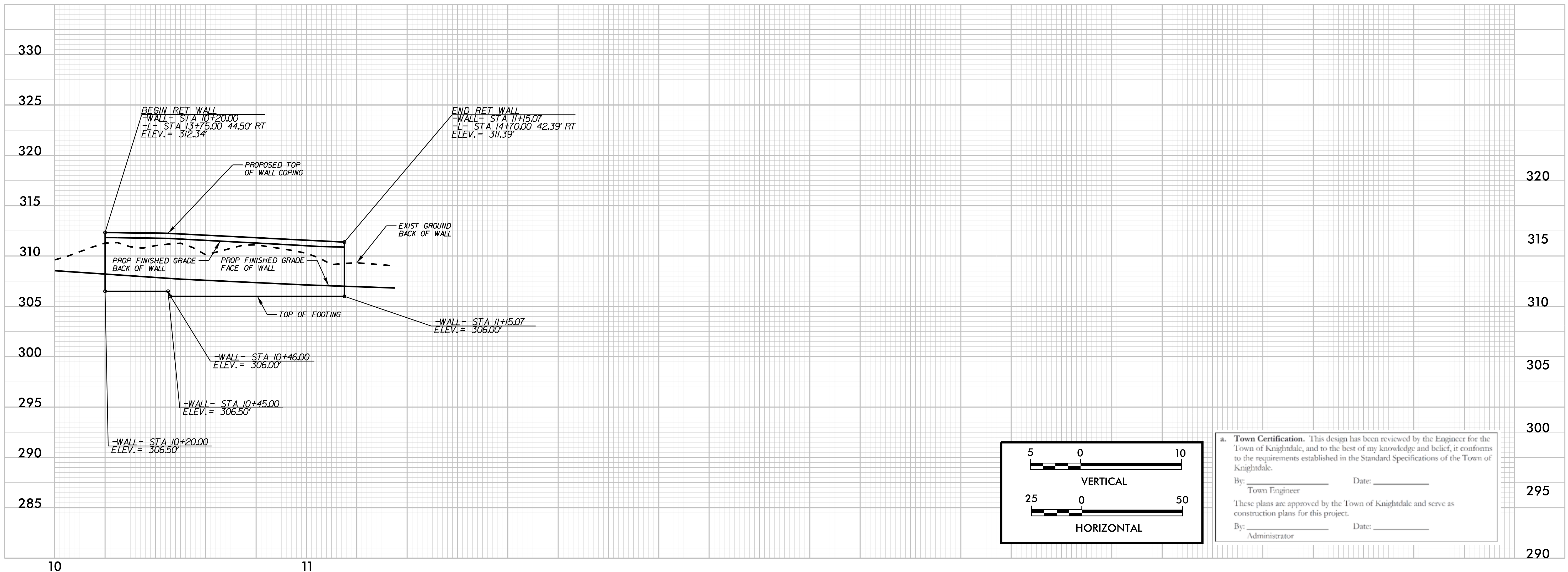
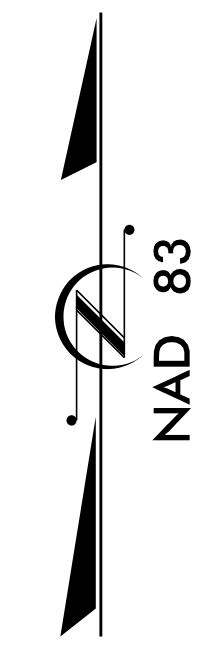
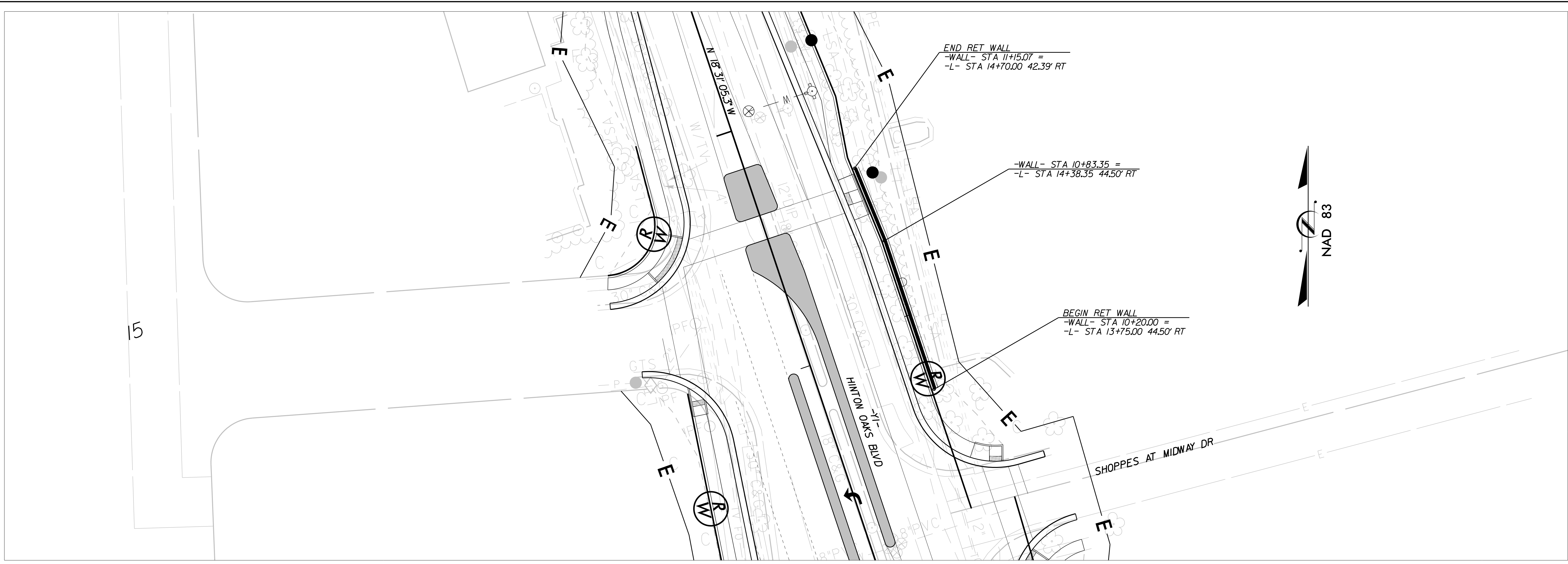

a. Town Certification. This design has been reviewed by the Engineer for the Town of Knightdale, and to the best of my knowledge and belief, it conforms to the requirements established in the Standard Specifications of the Town of Knightdale.

By: _____ Date: _____
Town Engineer

These plans are approved by the Town of Knightdale and serve as construction plans for this project.

By: _____ Date: _____
Administrator

No.	REVISIONS	DATE	BY

Kimley»Horn

© 2021
300 MORRIS STREET, SUITE 200, DURHAM, NC, 27701
PHONE: 919-682-3583
WWW.KIMLEY-HORN.COM
NC LICENSE #: F-0102

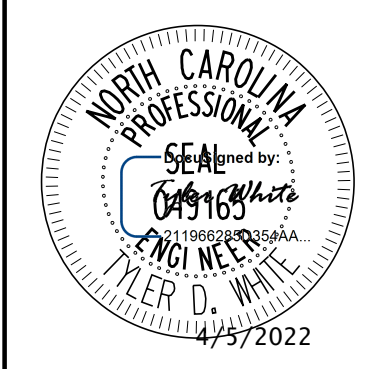

KHA PROJECT	013936008
DATE	4/4/2022
SCALE	1" = 20'
DESIGNED BY:	TDW
DRAWN BY:	LCK
CHECKED BY:	TDW

**RETAINING WALL
ENVELOPE**

**MERRITT HINTON OAKS
BLVD OFFSITE
IMPROVEMENTS**

NORTH CAROLINA
KNIGHTDALE

SHEET NUMBER
R2.02

PLAN FOR PROPOSED TRAFFIC CONTROL, MARKING & DELINEATION WAKE COUNTY

ROADWAY STANDARD DRAWINGS

THE FOLLOWING ROADWAY STANDARDS AS SHOWN IN "ROADWAY STANDARD DRAWINGS" - N.C. DEPARTMENT OF TRANSPORTATION - RALEIGH, N.C., DATED JANUARY 2018 ARE APPLICABLE TO THIS PROJECT AND BY REFERENCE HEREBY ARE CONSIDERED A PART OF THESE PLANS:

STD. NO.	TITLE
1101.01	WORK ZONE ADVANCE WARNING SIGNS
1101.02	TEMPORARY LANE CLOSURES
1101.03	TEMPORARY ROAD CLOSURES
1101.04	TEMPORARY SHOULDER CLOSURES
1101.11	TRAFFIC CONTROL DESIGN TABLES
1110.01	STATIONARY WORK ZONE SIGNS
1110.02	PORTABLE WORK ZONE SIGNS
1130.01	DRUMS
1135.01	CONES
1145.01	BARRICADES - TYPE III
1150.01	FLAGGING DEVICES
1180.01	SKINNY DRUMS
1205.01	PAVEMENT MARKINGS - LINE TYPES AND OFFSETS
1205.02	PAVEMENT MARKINGS - TWO LANE AND MULTI-LANE MARKINGS
1205.04	PAVEMENT MARKINGS - INTERSECTIONS
1205.05	PAVEMENT MARKINGS - TURN LANES
1205.07	PAVEMENT MARKINGS - PEDESTRIAN CROSSWALKS
1205.08	PAVEMENT MARKINGS - SYMBOLS AND WORD MESSAGES
1205.13	PAVEMENT MARKINGS - LANE REDUCTIONS
1250.01	RAISED PAVEMENT MARKERS - INSTALLATION SPACING
1251.01	RAISED PAVEMENT MARKERS - (PERMANENT AND TEMPORARY)

INDEX OF SHEETS

SHEET NO.	TITLE
R3.00	TRAFFIC CONTROL TITLE SHEET, LIST OF APPLICABLE ROADWAY STANDARD DRAWINGS, AND LEGEND
R3.01	GENERAL NOTES
R3.02	PHASING NOTES
R3.03	PHASE I PLANS AND DETAILS
R3.04	PHASE II PLANS AND DETAILS
R3.05	PHASE III PLANS AND DETAILS

LEGEND

- GENERAL**
- DIRECTION OF TRAFFIC FLOW
 - NORTH ARROW
 - PROPOSED PVMT.
 - WEDGING
 - WORK AREA
 - REMOVAL OF EXISTING PAVEMENT
 - TEMPORARY PAVEMENT
- TRAFFIC CONTROL DEVICES**
- TYPE I BARRICADE
 - TYPE II BARRICADE
 - TYPE III BARRICADE
 - CONE
 - DRUM
 - SKINNY DRUM
 - FLASHING ARROW PANEL (TYPE C)
 - STATIONARY SIGN
 - PORTABLE SIGN
 - STATIONARY OR PORTABLE SIGN
 - CRASH CUSHION
 - CHANGEABLE MESSAGE SIGN
 - TRUCK MOUNTED ATTENUATOR (TMA)
 - POLICE
 - FLAGGER
- PAVEMENT MARKINGS**
- CRYSTAL/CRYSTAL PAVEMENT MARKER
 - YELLOW/YELLOW PAVEMENT MARKER
 - CRYSTAL/RED PAVEMENT MARKER
 - PAVEMENT MARKING SYMBOLS

TEMPORARY PAVEMENT MARKING SCHEDULE

- PAVEMENT MARKING LINES**
- P1 - PAINT (4" WHITE, 2X) EDGELINE
 - P2 - PAINT (4" WHITE, 2X) SOLID LANE LINE
 - P3 - PAINT (4" WHITE, 2X) 10 FT. WHITE SKIP
 - P4 - PAINT (4" WHITE, 2X) 3' X 9'/SP MINISKIP
 - P10 - PAINT (4" YELLOW, 2X) EDGELINE
 - P13 - PAINT (4" YELLOW, 2X) DOUBLE CENTERLINE
 - P42 - PAINT (8" YELLOW, 2X) DIAGONAL
 - P61 - PAINT (24" WHITE, 2X) STOP BARS
 - P62 - PAINT (8" WHITE, 2X) CROSSWALK
- PAVEMENT MARKING SYMBOLS**
- P70 - PAINT 2X (LEFT TURN ARROW)
 - P71 - PAINT 2X (RIGHT TURN ARROW)
 - P72 - PAINT 2X (STRAIGHT ARROW)
 - P74 - PAINT 2X (COMBO RIGHT/STRAIGHT ARROW)
 - P100 - PAINT 2X (ALPHANUMERIC CHAR.)

Kimley»Horn
 © 2021
 300 MORRIS STREET, SUITE 200, DURHAM, NC, 27701
 PHONE: 919-682-3583
 WWW.KIMLEY-HORN.COM
 NC LICENSE #: F-0102



KHA PROJECT	013936008
DATE	4/4/2022
SCALE	AS SHOWN
DESIGNED BY:	TOW
DRAWN BY:	LCK
CHECKED BY:	TOW

TRAFFIC & PEDESTRIAN
 MANAGEMENT
 TITLE SHEET, INDEX OF
 SHEETS & LEGEND

MERRITT HINTON OAKS
 BLVD OFFSITE
 IMPROVEMENTS
 NORTH CAROLINA
 KNIGHTDALE

SHEET NUMBER
R3.00

4. Town Certification. This design has been reviewed by the Engineer for the Town of Knightdale, and to the best of my knowledge and belief, it conforms to the requirements established in the Standard Specifications of the Town of Knightdale.
 By: _____ Date: _____
 Town Engineer
 These plans are approved by the Town of Knightdale and serve as construction plans for this project.
 By: _____ Date: _____
 Administrator

PHASING NOTES

PHASE 1

WHILE MAINTAINING TRAFFIC USING RSD 1101.04 FOR SHOULDER CLOSURES AND RSD 1101.02 FOR LANE CLOSURES AS NECESSARY, PERFORM THE FOLLOWING:

**STEP 1:
INSTALL ADVANCE WARNING SIGNS IN ACCORDANCE WITH RSD 1101.01.**

**STEP 2:
INSTALL TRAFFIC CONTROL DEVICES AS SHOWN ON SHEET R3.03.**

**STEP 3:
AWAY FROM TRAFFIC CONSTRUCT PROPOSED IMPROVEMENTS ALONG -L- KNIGHTDALE BLVD AND -Y1- HINTON OAKS BLVD INCLUDING BUT NOT LIMITED TO CURB AND GUTTER, SIDEWALK, ALL ASSOCIATED DRAINAGE, AND PAVING UP TO BUT NOT INCLUDING THE FINAL SURFACE COURSE. DO NOT PERFORM WORK ON BOTH SIDES OF MEDIAN OF -L- KNIGHTDALE BLVD SIMULTANEOUSLY.**

NOTE: PROVIDE WEDGING AS REQUIRED TO ENSURE SMOOTH TRANSITIONS AND POSITIVE DRAINAGE.

PHASE 2

WHILE MAINTAINING TRAFFIC USING RSD 1101.04 FOR SHOULDER CLOSURES AND RSD 1101.02 FOR LANE CLOSURES AS NECESSARY, PERFORM THE FOLLOWING:

**STEP 1:
REMOVE EXISTING CONCRETE MEDIAN ISLAND. UTILIZE TEMPORARY PAVEMENT AS NECESSARY.**

**STEP 2:
INSTALL TRAFFIC CONTROL DEVICES AS SHOWN SHEET R3.04.**

**STEP 3:
AWAY FROM TRAFFIC CONSTRUCT PROPOSED IMPROVEMENTS ALONG -Y1- HINTON OAKS BLVD INCLUDING BUT NOT LIMITED TO CURB AND GUTTER, SIDEWALK, TEMPORARY PAVEMENT, ALL ASSOCIATED DRAINAGE, AND PAVING UP TO BUT NOT INCLUDING THE FINAL SURFACE COURSE.**

NOTE: PROVIDE WEDGING AS REQUIRED TO ENSURE SMOOTH TRANSITIONS AND POSITIVE DRAINAGE.

PHASE 3

WHILE MAINTAINING TRAFFIC USING RSD 1101.04 FOR SHOULDER CLOSURES AND RSD 1101.02 FOR LANE CLOSURES AS NECESSARY, PERFORM THE FOLLOWING:

**STEP 1:
INSTALL TRAFFIC CONTROL DEVICES AS SHOWN ON SHEET R3.05. MAINTAIN TEMPORARY PAVEMENT MARKINGS FOR SOUTHBOUND TRAFFIC ALONG -Y1- HINTON OAKS BLVD**

**STEP 2:
CONSTRUCT PROPOSED MONOLITHIC ISLANDS AND ALL ASSOCIATED DRAINAGE AS SHOWN ON SHEET R3.05.**

**STEP 2:
INSTALL FINAL ASPHALT SURFACE COURSE AND FINAL PAVEMENT MARKINGS, REMOVE ALL TRAFFIC CONTROL DEVICES AND OPEN ALL LANES TO TRAFFIC.**

Kimley»Horn
© 2021
300 MORRIS STREET, SUITE 200, DURHAM, NC, 27701
PHONE: 919-682-3583
WWW.KIMLEY-HORN.COM
NC LICENSE #: F-0102



KHA PROJECT	DATE	SCALE	DESIGNED BY:	DRAWN BY:	CHECKED BY:
013936008	4/4/2022	N/T/S	TDW	LCK	TDW

TRAFFIC MANAGEMENT
PHASING NOTES

MERRITT HINTON OAKS
BLVD OFFSITE
IMPROVEMENTS

SHEET NUMBER
R3.02

NORTH CAROLINA
KNIGHTDALE

4. Town Certification. This design has been reviewed by the Engineer for the Town of Knightdale, and to the best of my knowledge and belief, it conforms to the requirements established in the Standard Specifications of the Town of Knightdale.
By: _____ Date: _____
Town Engineer
These plans are approved by the Town of Knightdale and serve as construction plans for this project.
By: _____ Date: _____
Administrator

SECTION A-A

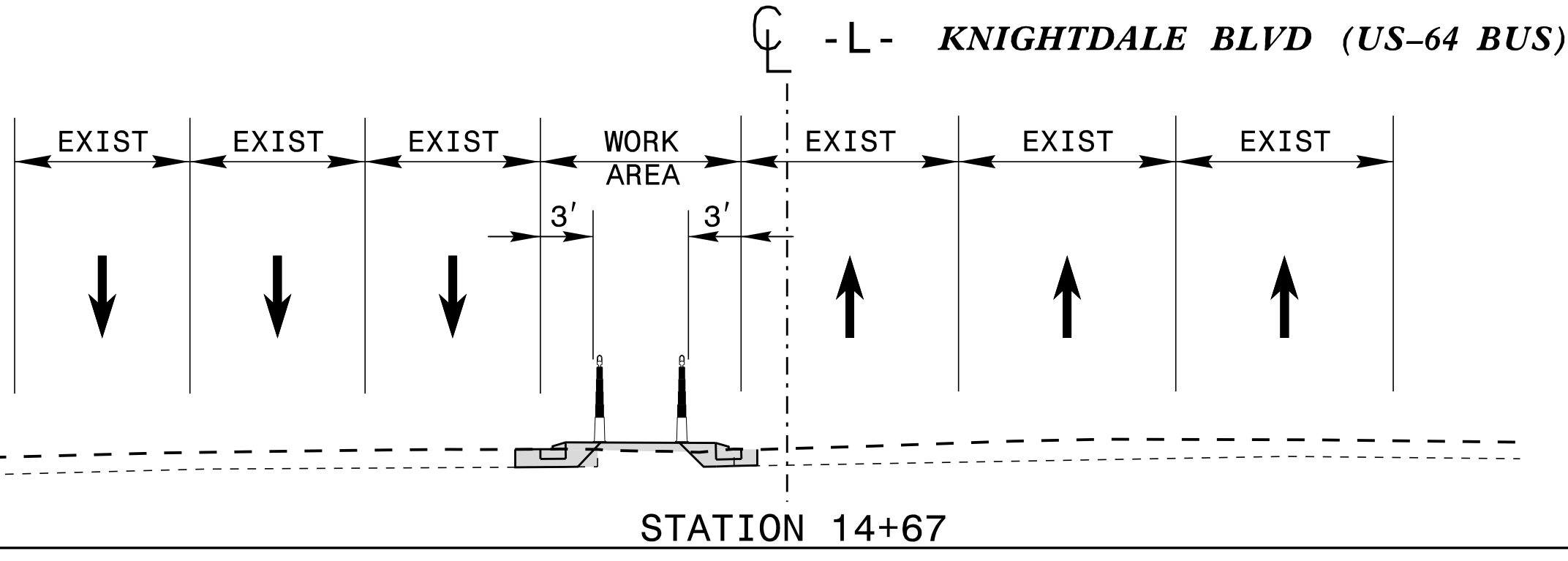

SECTION B-B

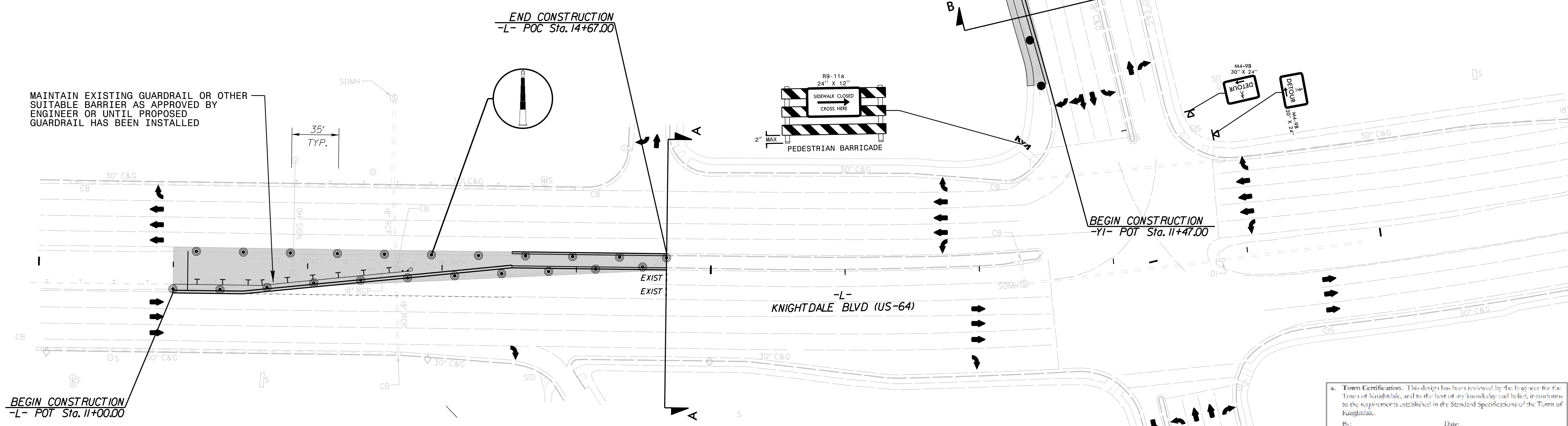
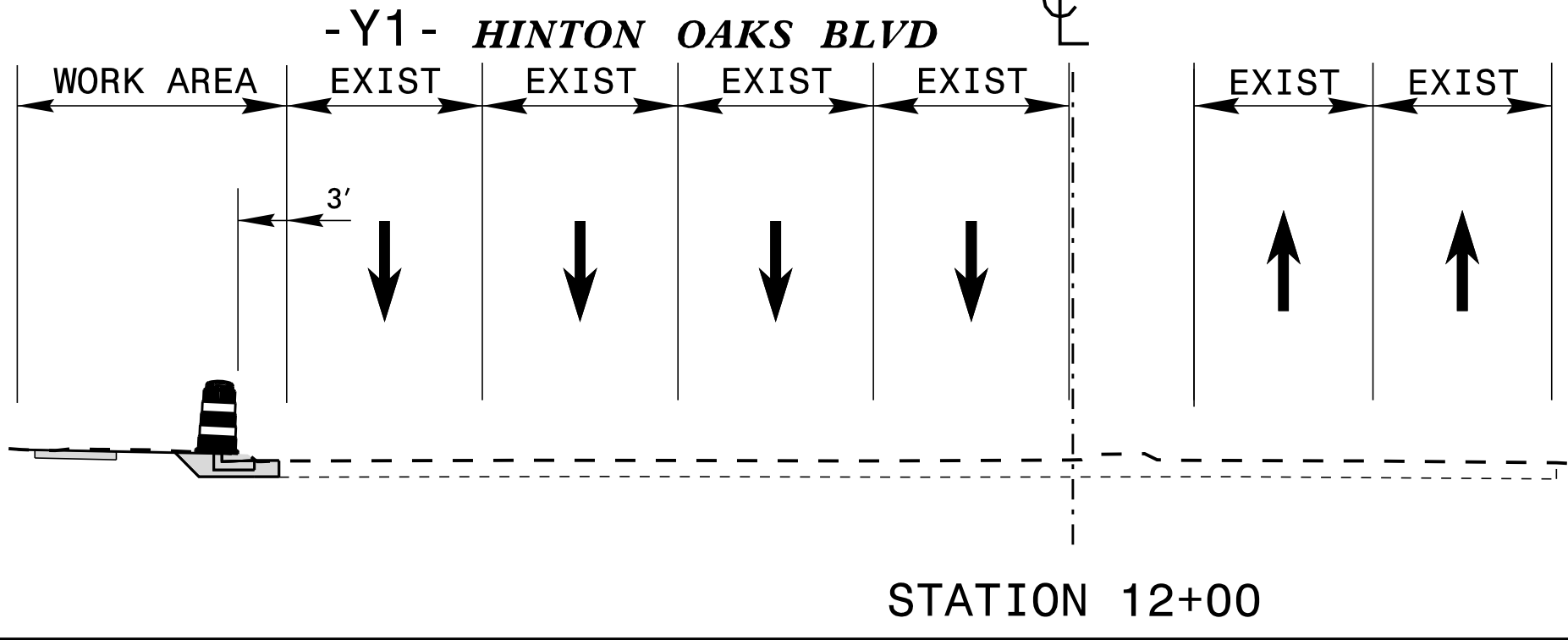

MAINTAIN EXISTING GUARDRAIL OR OTHER SUITABLE BARRIER AS APPROVED BY ENGINEER OR UNTIL PROPOSED GUARDRAIL HAS BEEN INSTALLED

4. Town Certification. This design has been reviewed by the Engineer for the Town of Knightdale, and to the best of my knowledge and belief, it conforms to the requirements established in the Standard Specifications of the Town of Knightdale.

By: _____ Date: _____
Town Engineer

These plans are approved by the Town of Knightdale and serve as construction plans for this project.

By: _____ Date: _____
Administrator

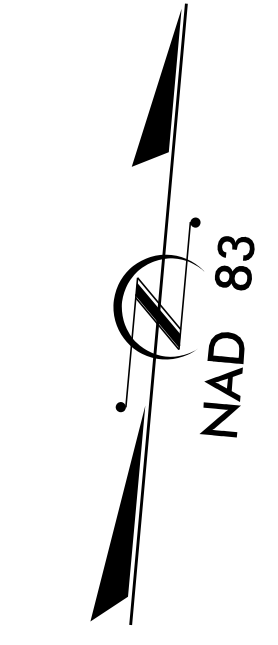

NO.	REVISIONS	DATE	BY

Kimley»Horn

© 2021
300 MORRIS STREET, SUITE 200, DURHAM, NC, 27701
PHONE: 919-682-3583
WWW.KIMLEY-HORN.COM
NC LICENSE # F-0102

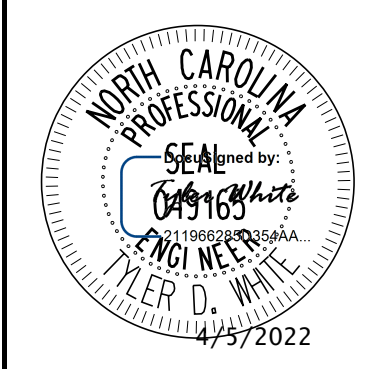

KHA PROJECT	013936008
DATE	4/4/2022
SCALE	1" = 40'
DESIGNED BY:	TOW
DRAWN BY:	LCK
CHECKED BY:	TOW

TRAFFIC AND PEDESTRIAN MANAGEMENT PLAN - PHASE I

MERRITT HINTON OAKS BLVD OFFSITE IMPROVEMENTS

NORTH CAROLINA

SHEET NUMBER
R3.03

4/4/2022 K:\DUR_Roadway\013936008 - Midway Business Park\Plan\MP\TMP Sheets\013936008_psh_imp_ldgn

SIGNING LEGEND

- DENOTES EXISTING SIGN
- DENOTES NEW "U" CHANNEL POST / PROPOSED SIGN LOCATION
- DENOTES EXISTING "U" CHANNEL POST / EXISTING SIGN LOCATION
- DENOTES SIGNALIZED INTERSECTION
- DENOTES EXISTING SIGNAL

SIGNING NOTES

1. REMOVE AND DISPOSE OF EXISTING "U" CHANNEL POST.
2. ERECT EXISTING SIGN ON NEW "U" CHANNEL POST.
3. REMOVE AND DISPOSE OF EXISTING SIGNS AND "U" CHANNEL POST.
4. THE BACKGROUND FOR TYPE E & F SIGNS SHALL BE TYPE C REFLECTIVE SHEETING.
5. ALL STREET NAME SIGNS SHALL ADHERE TO 2009 MUTCD. ALL STREET NAME SIGNS SHALL BE APPROVED BY THE TRANSPORTATION AND FACILITIES DEPARTMENT STAFF PRIOR TO INSTALLATION.
6. THE RRFB SIGNS ARE TO BE INSTALLED AT LOCATIONS INDICATED IN THE PLANS AND SPECIFICATIONS. THE RRFB SIGN MATERIALS SHALL BE PER MUTCD, NCDOT, AND APPLICABLE ADA STANDARDS. THE RRFB SIGNS ARE TO BE INSTALLED PER MUTCD, NCDOT, AND APPLICABLE ADA STANDARDS.

PAVEMENT MARKING LINES

- T1 - THERMOPLASTIC (4" WHITE, 90 MILS) EDGE LINE
- T2 - THERMOPLASTIC (4" WHITE, 90 MILS) LANE LINE
- T3 - THERMOPLASTIC (4" WHITE, 90 MILS) 10' - 9" SP SKIP
- T4 - THERMOPLASTIC (4" WHITE, 90 MILS) 3' - 9" SP MINISKIP
- T5 - THERMOPLASTIC (4" WHITE, 90 MILS) 2' - 6" SP MINI SKIP
- T13 - THERMOPLASTIC (4" YELLOW, 90 MILS) YELLOW DOUBLE CENTER
- T40 - THERMOPLASTIC (8" WHITE, 90 MILS) GORELINE
- T41 - THERMOPLASTIC (8" WHITE, 90 MILS) DIAGONAL LINE
- T42 - THERMOPLASTIC (8" YELLOW, 90 MILS) DIAGONAL LINE
- T61 - THERMOPLASTIC (24" WHITE, 90 MILS) STOPBAR
- T62 - THERMOPLASTIC (24" WHITE, 90 MILS) CROSSWALK LINE

PAVEMENT MARKING SYMBOLS

- T70 - THERMOPLASTIC (LEFT TURN ARROW) (90 MILS)
- T71 - THERMOPLASTIC (RIGHT TURN ARROW) (90 MILS)
- T74 - THERMOPLASTIC (COMBO RIGHT/STRAIGHT ARROW) (90 MILS)
- T100 - THERMOPLASTIC (ALPHANUMERIC CHAR.) (90 MILS)

PAVEMENT MARKING NOTES:

1. CONTRACTOR TO TIE PROPOSED MARKINGS TO EXISTING MARKINGS AT PROJECT LIMITS.
2. CONTRACTOR SHALL MILL ANY EXISTING MARKINGS OR SYMBOLS IN CONFLICT WITH PROPOSED MARKINGS.
3. RAISED REFLECTIVE PAVEMENT MARKERS ARE TO BE PLACED ACCORDING TO NCDOT ROADWAY STANDARD DRAWINGS.
4. ALL RAISED REFLECTIVE PAVEMENT MARKERS TO BE SNOWPLOWABLE.

PAVEMENT MARKER LEGEND

- CRYSTAL / RED PAVEMENT MARKER
- YELLOW / YELLOW PAVEMENT MARKER
- DIRECTION OF TRAFFIC FLOW

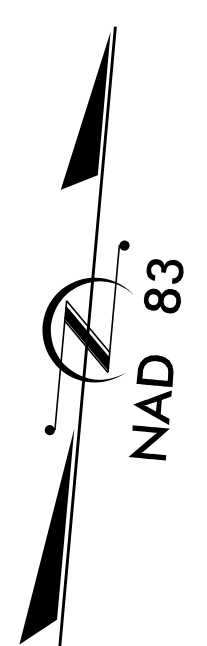
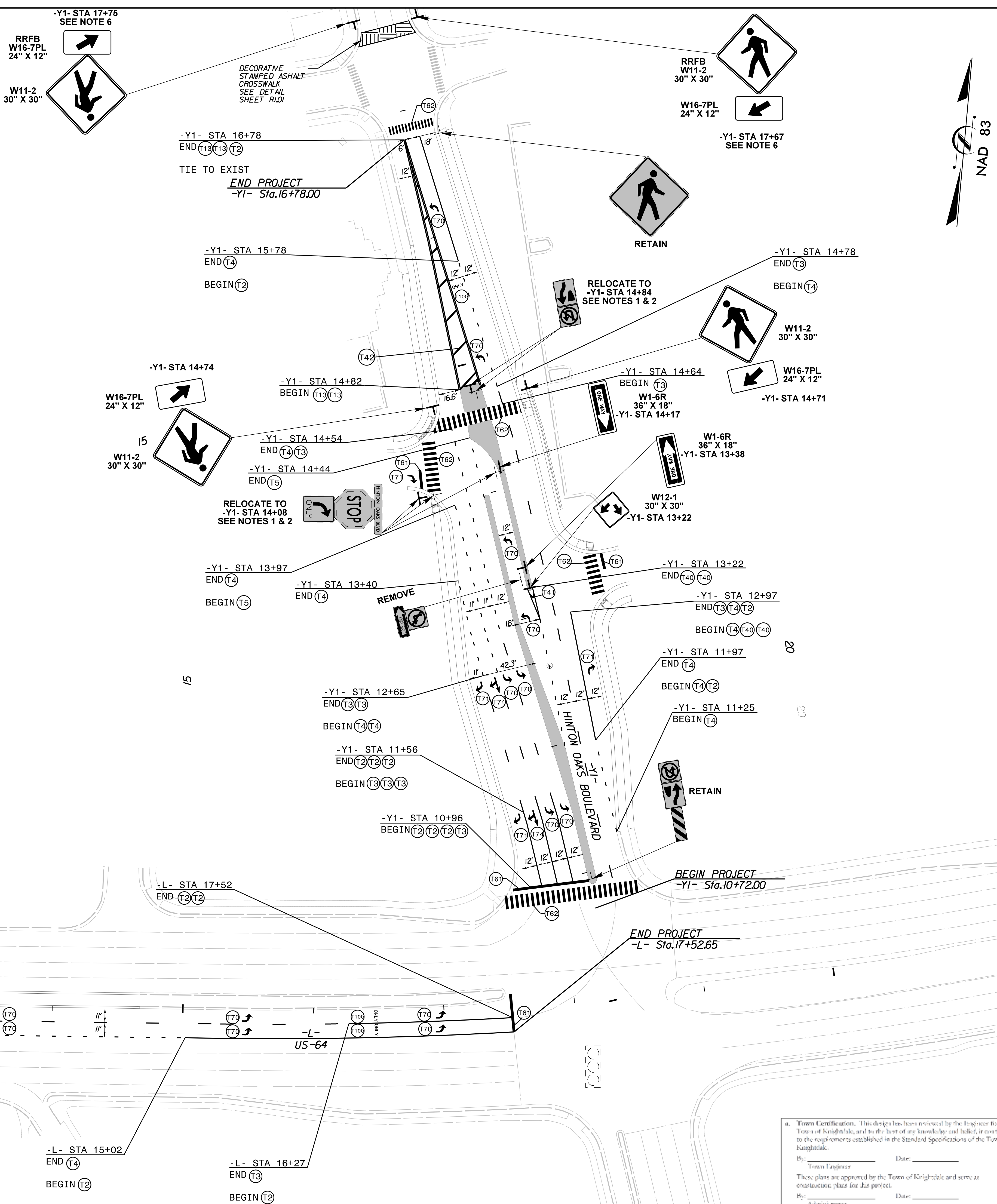

NO.	REVISIONS	DATE	BY

Kimley»Horn

© 2021
300 MORRIS STREET, SUITE 200, DURHAM, NC, 27701
PHONE: 919-682-3583
WWW.KIMLEY-HORN.COM
NC LICENSE # F-0102

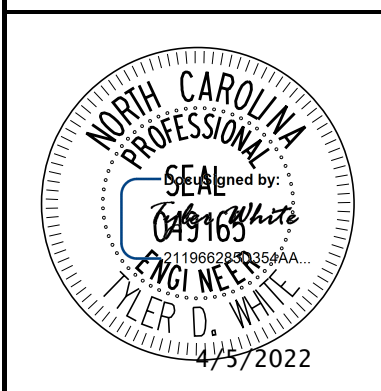

KHA PROJECT	013936008
DATE	4/4/2022
SCALE	1" = 40'
DESIGNED BY:	TDW
DRAWN BY:	LCK
CHECKED BY:	TDW

SIGNING AND MARKING PLAN

MERRITT HINTON OAKS BLVD OFFSITE IMPROVEMENTS

NORTH CAROLINA

SHEET NUMBER
R4.00

K:\DUR_Roadway\013936008 - Midway Business Park\Plan\PM & Signing\013936008_psh_PMP.dgn

4. Town Certification. This design has been reviewed by the Engineer for the Town of Knightdale, and to the best of my knowledge and belief, it conforms to the requirements established in the Standard Specifications of the Town of Knightdale.

By: _____ Date: _____
Town Engineer

These plans are approved by the Town of Knightdale and serve as construction plans for this project.

By: _____ Date: _____
Administrator

K:\DUR_Roadway\013936008 - Midway Business Park\Plan\Erosion Control\013936008_ero_psh_4.dgn

EROSION CONTROL MEASURES	
INLET PROTECTION	
TEMPORARY SEDIMENT FENCE	
TEMPORARY ROCK SILT CHECK (TYPE A)	
TREE PROTECTION FENCE	
TEMPORARY WADDLE	

NOTES:
 1. TOTAL DISTURBED AREA FOR OFFSITE IMPROVEMENTS = 0.75 AC.
 3. ALL PUBLIC STREETS TO BE KEPT CLEAN OF SEDIMENT AT ALL TIMES OR A WASH STATION WILL BE REQUIRED.

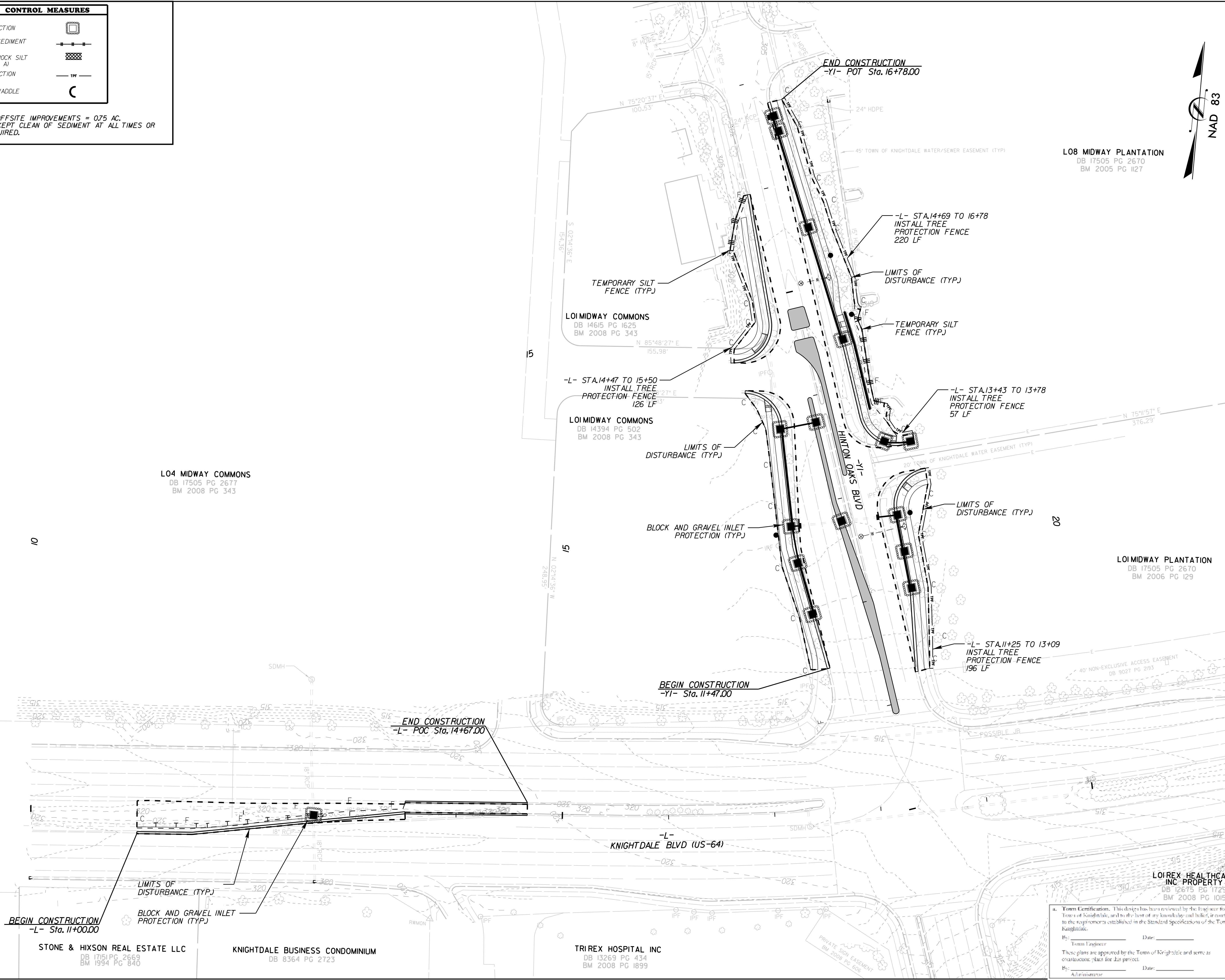

LO8 MIDWAY PLANTATION
 DB 17505 PG 2670
 BM 2005 PG 1127

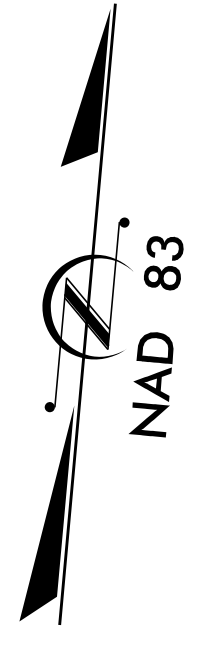

LO4 MIDWAY COMMONS
 DB 17505 PG 2677
 BM 2008 PG 343

LO1 MIDWAY COMMONS
 DB 14615 PG 1625
 BM 2008 PG 343

LO1 MIDWAY COMMONS
 DB 14394 PG 502
 BM 2008 PG 343

LO1 MIDWAY PLANTATION
 DB 17505 PG 2670
 BM 2006 PG 129

LOIREX HEALTHCARE
 INC PROPERTY
 DB 12675 PG 1729
 BM 2008 PG 1015

STONE & HIXSON REAL ESTATE LLC
 DB 17151 PG 2669
 BM 1994 PG 840

KNIGHTDALE BUSINESS CONDOMINIUM
 DB 8364 PG 2723

TRIREX HOSPITAL INC
 DB 13269 PG 434
 BM 2008 PG 1899

4. Town Certification. This design has been reviewed by the Engineer for the Town of Knightdale, and to the best of my knowledge and belief, it conforms to the requirements established in the Standard Specifications of the Town of Knightdale.
 Town Engineer _____ Date: _____
 These plans are approved by the Town of Knightdale and serve as construction plans for this project.
 By: _____ Date: _____
 Administrator

No.	REVISIONS	DATE	BY

Kimley»Horn
 © 2021
 300 MORRIS STREET, SUITE 200, DURHAM, NC, 27701
 PHONE: 919-682-3583
 WWW.KIMLEY-HORN.COM
 NC LICENSE # F-0102

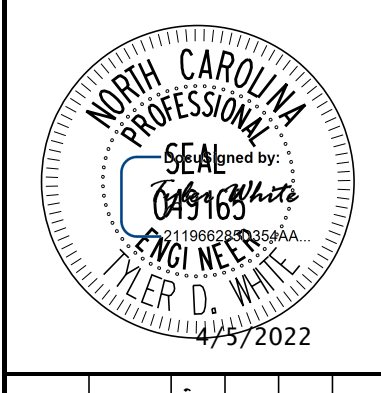

KHA PROJECT	013936008
DATE	4/4/2022
SCALE	1" = 40'
DESIGNED BY:	TDW
DRAWN BY:	LCK
CHECKED BY:	TDW

EROSION CONTROL PLAN

MERRITT HINTON OAKS BLVD OFFSITE IMPROVEMENTS

SHEET NUMBER
R5.00

K:\DUR_Roadway\013936008 - Midway_Business_Park\Plan\Erosion_Control\013936008_psh_era_DTL.dgn 4/4/2022

CONSTRUCTION SEQUENCE

CONSTRUCTION SPECIFICATIONS

- Request preconstruction meeting.
- Obtain grading permit;
- Install all erosion control measures as shown;
- Obtain certificate of compliance through on-site inspection by Erosion Control Officer;
- Proceed with grading;
- Clean sediment basins when one-half full;
- Seed and mulch denuded area within 15 days or duration shown on ground stabilization requirements, whichever is shorter, after any phase of grading;
- Maintain soil erosion control measures until permanent ground cover is established;
- Request final approval by Erosion Control Officer;
- Remove soil erosion control measures and stabilize these areas.

MAINTENANCE

Follow the construction sequence throughout project development. When changes in construction activities are needed, amend the sequence schedule in advance to maintain management control.

Notification of Land Resources Sediment and Erosion Control Self-Inspection Program:

The Sedimentation Pollution Control Act was amended in 2006 to require that persons responsible for land-disturbing activities inspect a project after each phase of the project to make sure that the approved erosion and sedimentation control plan is being followed. Rules detailing the documentation of these inspections took effect October 1, 2010. The self-inspection program is separate from the weekly self-monitoring program of the NPDES Stormwater Permit for Construction Activities. The focus of the self-inspection report is the installation and maintenance of erosion and sedimentation control measures according to the approved plan. The inspections must be conducted after each phase of the project, and continue until permanent ground cover is established. In accordance with NCGS 113A-54J and 15A NCAC 4B.0131, The Self-Inspection Report Form is available as an Excel spreadsheet from <http://portal.ncdenr.org/web/1r/erosion>. If you have questions or cannot access the form, please contact NC DENR Division of Land Resources at (919) 791-4200.

MAINTENANCE PLAN

- The Contractor shall inspect all erosion and sediment control practices for stability and operation within 24 hours following every runoff producing 0.5" rainfall (in a 24 hour period) but in no case less than once every week. Any needed repairs will be made immediately by the Contractor to maintain all practices as designed. Also per National Pollutant Discharge Elimination System (NPDES) general stormwater permit, a rain gauge must be installed on site. The rain gauge must be kept onsite and inspections by the Contractor must be made and logged after every half inch of rainfall and once a week.
- The Contractor shall remove sediment from sediment basin when storage capacity has been approximately 50% filled. Gravel will be cleaned or replaced when the sediment pool no longer drains properly.
- The Contractor shall remove sediment from behind silt fence when it becomes 0.5 feet deep at the fence. Silt fence will be repaired as necessary to maintain a barrier.
- The Contractor shall fertilize, reseed as necessary, and mulch all seeded areas according to specifications in the vegetative plan to maintain a vigorous, dense vegetative cover.
- The Contractor must inspect all outlets where stormwater runoff leaves the site and evaluate the effect on nearby streams or wetlands. Corrective action must be taken if sediment is deposited off site or into stream or wetland, or causes a visible increase in turbidity of any waterbody.
- The Contractor shall provide ground cover on exposed slopes or other areas within the timeframe specified in the stabilization table or sooner of completion of any phase of grading.

GROUND STABILIZATION REQUIREMENTS

Contractor shall stabilize (temporary or permanent) all disturbed areas within 7 or 14 days of termination of grading operations per the following guidelines.

Perimeter dikes, swales, ditches and slopes - 7 days
High Quality Water Zones - 7 days
Slopes 2:1 or steeper - 7 days
Slopes between 2:1 and 3:1 greater than 10' in length - 7 days
Slopes between 2:1 and 3:1 less than 10' in length - 14 days
Slopes between 3:1 and 4:1 less than 50' in length - 14 days
Slopes between 3:1 and 4:1 greater than 50' in length - 7 days
Slopes flatter than 4:1 - 14 days

VEGETATIVE PLAN (NC DENR 6J1)

The kinds of seed and fertilizer, and the rates of application of seed, fertilizer, and limestone shall be as stated below. During periods of overlapping dates, the kind of seed to be used shall be determined by the Engineer.

Date	Type	Planting Rate
Mar. 1-Aug. 31	Tall Fescue Centipede Hulled Common Bermudagrass Fertilizer Limestone	50 lbs./acre 5 lbs./acre 25 lbs./acre 500 lbs./acre 4000 lbs./acre
Sep. 1-Feb. 28	Tall Fescue Centipede Unhulled Common Bermudagrass Fertilizer Limestone	50 lbs./acre 5 lbs./acre 35 lbs./acre 500 lbs./acre 4000 lbs./acre

Slopes (2:1 and steeper) and Waste & Borrow Locations

Jan. 1-Dec. 31	Tall Fescue Unhulled Common Bermudagrass Fertilizer Limestone	75 lbs./acre 35 lbs./acre 500 lbs./acre 4000 lbs./acre
----------------	--	---

Approved Tall Fescue Cultivars

Adventure	Adventure II	Amigo	Anthem
Apache	Apache II	Arid	Austin
Brookstone	Coranzo	Bonanza II	Chapel Hill
Chesapeake	Chieftain	Coronado	Crossfire II
Debutante	Duster	Falcon	Falcon II
Finelawn Petite	Finelawn	Finelawn I	Genesis II
Grande	Guardian	Hawk	Hounddog
Jaguar	Jaguar III	Kentucky 31	Kitty
Monarch	Montauk	Mustang	Olympic
Pacer	Phoenix	Pixie	Pyramid
Rebel	Shenandoah	Rebel II	Renegade
Safari	Tombawik	Triumph	Titan
Wolfpack	Wrangle	Tribe	Vegas

SEEDING AND MULCHING

On cut and fill slopes 2:1 or steeper, add 30* (123kg) Sericea Lespedeza January 1-December 31.

Fertilizer shall be 10-20-20 analysis. Upon written approval of the Engineer, a different analysis of fertilizer may be used provided the 1-2-2 ratio is maintained and the rate of application adjusted to provide the same amount of plant food as a 10-20-20 analysis.

SEEDBED PREPARATION

The Contractor shall cut and satisfactorily dispose of weeds or other unacceptable growth on the areas to be seeded. Uneven and rough areas outside of the graded section, such as crop rows, form contours, ditches, and ditch spoil banks, fence line and hedgerow, soil accumulations, and other minor irregularities which cannot be obliterated by normal seedbed preparation operations, shall be shaped and smoothed as directed by the Engineer to provide for more effective seeding and for ease of subsequent mowing operations.

The soil shall then be scarified or otherwise loosened to a depth of not less than 5 inches except as otherwise provided below or otherwise directed by the Engineer. Clods shall be broken and the top 2 to 3 inches of soil shall be worked into an acceptable seedbed by the use of soil pulverizers, drag scarifiers, harrows, or by other methods approved by the Engineer. All rock and debris 3 inches or larger shall be removed on median, shoulder, and ditch cut or fill slopes which are 3:1 or flatter, prior to the application of seed and fertilizer.

On cut slopes that are 2:1 and steeper, both the depth of preparation and the degree of smoothness of the seedbed may be reduced as permitted by the Engineer, but in all cases the slope surface shall be scarified, grooved, trenched, or punctured so as to provide pockets, ridges, or trenches in which the seeding materials can lodge. Contractor shall be responsible for providing the required seed bed. It may be necessary to seed these sections with a hydro-seed.

On cut slopes that are either 2:1 or steeper, the Engineer may permit the preparation of a partial or complete seedbed during the grading of the slope, if at the time of seeding and mulching operations such preparation is still in a condition acceptable to the Engineer, additional seedbed preparation may be reduced or eliminated.

Seedbed preparation within 2 feet of the edge of any pavement shall be limited to a depth of 2 to 3 inches.

The preparation of seedbeds shall not be done when the soil is frozen, extremely wet, or when the Engineer determines that it is an otherwise unfavorable working condition.

APPLYING AND COVERING LIMESTONE, FERTILIZER, AND SEED

A) GENERAL:

Seasonal limitation for seeding operations; the kinds of grades of fertilizers; the kinds of seed; and the rates of application of limestone, fertilizer, and seed shall be as stated in the special provisions.

Equipment to be used for the application, covering, or compaction of limestone, fertilizer, and seed shall have been approved by the Engineer before being used on the project. Approval may be revoked at any time if equipment is not maintained in satisfactory working condition, or if the equipment operation damages the seed.

Limestone, fertilizer, and seed shall be applied within 24 hours after completion of seedbed preparation unless otherwise permitted by the Engineer, but no limestone or fertilizer shall be distributed and no seed shall be sown when the Engineer determines the weather and soil conditions are unfavorable for such operations.

During the application of fertilizer, adequate precautions shall be taken to prevent damage to traffic, structures, guardrails, traffic control devices, or any other appurtenances. The Contractor shall either provide adequate drainage covering or change methods of application as required to avoid such damage. When such damage occurs the Contractor shall repair it, including any cleaning that may be necessary.

VEGETATIVE PLAN (NC DENR 6J1)

The kinds of seed and fertilizer, and the rates of application of seed, fertilizer, and limestone shall be as stated below. During periods of overlapping dates, the kind of seed to be used shall be determined by the Engineer.

Date	Type	Planting Rate
Mar. 1-Aug. 31	Tall Fescue Centipede Hulled Common Bermudagrass Fertilizer Limestone	50 lbs./acre 5 lbs./acre 25 lbs./acre 500 lbs./acre 4000 lbs./acre
Sep. 1-Feb. 28	Tall Fescue Centipede Unhulled Common Bermudagrass Fertilizer Limestone	50 lbs./acre 5 lbs./acre 35 lbs./acre 500 lbs./acre 4000 lbs./acre

Slopes (2:1 and steeper) and Waste & Borrow Locations

Jan. 1-Dec. 31	Tall Fescue Unhulled Common Bermudagrass Fertilizer Limestone	75 lbs./acre 35 lbs./acre 500 lbs./acre 4000 lbs./acre
----------------	--	---

Approved Tall Fescue Cultivars

Adventure	Adventure II	Amigo	Anthem
Apache	Apache II	Arid	Austin
Brookstone	Coranzo	Bonanza II	Chapel Hill
Chesapeake	Chieftain	Coronado	Crossfire II
Debutante	Duster	Falcon	Falcon II
Finelawn Petite	Finelawn	Finelawn I	Genesis II
Grande	Guardian	Hawk	Hounddog
Jaguar	Jaguar III	Kentucky 31	Kitty
Monarch	Montauk	Mustang	Olympic
Pacer	Phoenix	Pixie	Pyramid
Rebel	Shenandoah	Rebel II	Renegade
Safari	Tombawik	Triumph	Titan
Wolfpack	Wrangle	Tribe	Vegas

SEEDING AND MULCHING

On cut and fill slopes 2:1 or steeper, add 30* (123kg) Sericea Lespedeza January 1-December 31.

Fertilizer shall be 10-20-20 analysis. Upon written approval of the Engineer, a different analysis of fertilizer may be used provided the 1-2-2 ratio is maintained and the rate of application adjusted to provide the same amount of plant food as a 10-20-20 analysis.

SEEDBED PREPARATION

The Contractor shall cut and satisfactorily dispose of weeds or other unacceptable growth on the areas to be seeded. Uneven and rough areas outside of the graded section, such as crop rows, form contours, ditches, and ditch spoil banks, fence line and hedgerow, soil accumulations, and other minor irregularities which cannot be obliterated by normal seedbed preparation operations, shall be shaped and smoothed as directed by the Engineer to provide for more effective seeding and for ease of subsequent mowing operations.

The soil shall then be scarified or otherwise loosened to a depth of not less than 5 inches except as otherwise provided below or otherwise directed by the Engineer. Clods shall be broken and the top 2 to 3 inches of soil shall be worked into an acceptable seedbed by the use of soil pulverizers, drag scarifiers, harrows, or by other methods approved by the Engineer. All rock and debris 3 inches or larger shall be removed on median, shoulder, and ditch cut or fill slopes which are 3:1 or flatter, prior to the application of seed and fertilizer.

On cut slopes that are 2:1 and steeper, both the depth of preparation and the degree of smoothness of the seedbed may be reduced as permitted by the Engineer, but in all cases the slope surface shall be scarified, grooved, trenched, or punctured so as to provide pockets, ridges, or trenches in which the seeding materials can lodge. Contractor shall be responsible for providing the required seed bed. It may be necessary to seed these sections with a hydro-seed.

On cut slopes that are either 2:1 or steeper, the Engineer may permit the preparation of a partial or complete seedbed during the grading of the slope, if at the time of seeding and mulching operations such preparation is still in a condition acceptable to the Engineer, additional seedbed preparation may be reduced or eliminated.

Seedbed preparation within 2 feet of the edge of any pavement shall be limited to a depth of 2 to 3 inches.

The preparation of seedbeds shall not be done when the soil is frozen, extremely wet, or when the Engineer determines that it is an otherwise unfavorable working condition.

APPLYING AND COVERING LIMESTONE, FERTILIZER, AND SEED

A) GENERAL:

Seasonal limitation for seeding operations; the kinds of grades of fertilizers; the kinds of seed; and the rates of application of limestone, fertilizer, and seed shall be as stated in the special provisions.

Equipment to be used for the application, covering, or compaction of limestone, fertilizer, and seed shall have been approved by the Engineer before being used on the project. Approval may be revoked at any time if equipment is not maintained in satisfactory working condition, or if the equipment operation damages the seed.

Limestone, fertilizer, and seed shall be applied within 24 hours after completion of seedbed preparation unless otherwise permitted by the Engineer, but no limestone or fertilizer shall be distributed and no seed shall be sown when the Engineer determines the weather and soil conditions are unfavorable for such operations.

During the application of fertilizer, adequate precautions shall be taken to prevent damage to traffic, structures, guardrails, traffic control devices, or any other appurtenances. The Contractor shall either provide adequate drainage covering or change methods of application as required to avoid such damage. When such damage occurs the Contractor shall repair it, including any cleaning that may be necessary.

VEGETATIVE PLAN (NC DENR 6J1)

The kinds of seed and fertilizer, and the rates of application of seed, fertilizer, and limestone shall be as stated below. During periods of overlapping dates, the kind of seed to be used shall be determined by the Engineer.

Date	Type	Planting Rate
Mar. 1-Aug. 31	Tall Fescue Centipede Hulled Common Bermudagrass Fertilizer Limestone	50 lbs./acre 5 lbs./acre 25 lbs./acre 500 lbs./acre 4000 lbs./acre
Sep. 1-Feb. 28	Tall Fescue Centipede Unhulled Common Bermudagrass Fertilizer Limestone	50 lbs./acre 5 lbs./acre 35 lbs./acre 500 lbs./acre 4000 lbs./acre

Slopes (2:1 and steeper) and Waste & Borrow Locations

Jan. 1-Dec. 31	Tall Fescue Unhulled Common Bermudagrass Fertilizer Limestone	75 lbs./acre 35 lbs./acre 500 lbs./acre 4000 lbs./acre
----------------	--	---

Approved Tall Fescue Cultivars

Adventure	Adventure II	Amigo	Anthem
Apache	Apache II	Arid	Austin
Brookstone	Coranzo	Bonanza II	Chapel Hill
Chesapeake	Chieftain	Coronado	Crossfire II
Debutante	Duster	Falcon	Falcon II
Finelawn Petite	Finelawn	Finelawn I	Genesis II
Grande	Guardian	Hawk	Hounddog
Jaguar	Jaguar III	Kentucky 31	Kitty
Monarch	Montauk	Mustang	Olympic
Pacer	Phoenix	Pixie	Pyramid
Rebel	Shenandoah	Rebel II	Renegade
Safari	Tombawik	Triumph	Titan
Wolfpack	Wrangle	Tribe	Vegas

SEEDING AND MULCHING

On cut and fill slopes 2:1 or steeper, add 30* (123kg) Sericea Lespedeza January 1-December 31.

Fertilizer shall be 10-20-20 analysis. Upon written approval of the Engineer, a different analysis of fertilizer may be used provided the 1-2-2 ratio is maintained and the rate of application adjusted to provide the same amount of plant food as a 10-20-20 analysis.

SEEDBED PREPARATION

The Contractor shall cut and satisfactorily dispose of weeds or other unacceptable growth on the areas to be seeded. Uneven and rough areas outside of the graded section, such as crop rows, form contours, ditches, and ditch spoil banks, fence line and hedgerow, soil accumulations, and other minor irregularities which cannot be obliterated by normal seedbed preparation operations, shall be shaped and smoothed as directed by the Engineer to provide for more effective seeding and for ease of subsequent mowing operations.

The soil shall then be scarified or otherwise loosened to a depth of not less than 5 inches except as otherwise provided below or otherwise directed by the Engineer. Clods shall be broken and the top 2 to 3 inches of soil shall be worked into an acceptable seedbed by the use of soil pulverizers, drag scarifiers, harrows, or by other methods approved by the Engineer. All rock and debris 3 inches or larger shall be removed on median, shoulder, and ditch cut or fill slopes which are 3:1 or flatter, prior to the application of seed and fertilizer.

On cut slopes that are 2:1 and steeper, both the depth of preparation and the degree of smoothness of the seedbed may be reduced as permitted by the Engineer, but in all cases the slope surface shall be scarified, grooved, trenched, or punctured so as to provide pockets, ridges, or trenches in which the seeding materials can lodge. Contractor shall be responsible for providing the required seed bed. It may be necessary to seed these sections with a hydro-seed.

On cut slopes that are either 2:1 or steeper, the Engineer may permit the preparation of a partial or complete seedbed during the grading of the slope, if at the time of seeding and mulching operations such preparation is still in a condition acceptable to the Engineer, additional seedbed preparation may be reduced or eliminated.

Seedbed preparation within 2 feet of the edge of any pavement shall be limited to a depth of 2 to 3 inches.

The preparation of seedbeds shall not be done when the soil is frozen, extremely wet, or when the Engineer determines that it is an otherwise unfavorable working condition.

APPLYING AND COVERING LIMESTONE, FERTILIZER, AND SEED

A) GENERAL:

Seasonal limitation for seeding operations; the kinds of grades of fertilizers; the kinds of seed; and the rates of application of limestone, fertilizer, and seed shall be as stated in the special provisions.

Equipment to be used for the application, covering, or compaction of limestone, fertilizer, and seed shall have been approved by the Engineer before being used on the project. Approval may be revoked at any time if equipment is not maintained in satisfactory working condition, or if the equipment operation damages the seed.

Limestone, fertilizer, and seed shall be applied within 24 hours after completion of seedbed preparation unless otherwise permitted by the Engineer, but no limestone or fertilizer shall be distributed and no seed shall be sown when the Engineer determines the weather and soil conditions are unfavorable for such operations.

During the application of fertilizer, adequate precautions shall be taken to prevent damage to traffic, structures, guardrails, traffic control devices, or any other appurtenances. The Contractor shall either provide adequate drainage covering or change methods of application as required to avoid such damage. When such damage occurs the Contractor shall repair it, including any cleaning that may be necessary.

VEGETATIVE PLAN (NC DENR 6J1)

The kinds of seed and fertilizer, and the rates of application of seed, fertilizer, and limestone shall be as stated below. During periods of overlapping dates, the kind of seed to be used shall be determined by the Engineer.

Date	Type	Planting Rate
Mar. 1-Aug. 31	Tall Fescue Centipede Hulled Common Bermudagrass Fertilizer Limestone	50 lbs./acre 5 lbs./acre 25 lbs./acre 500 lbs./acre 4000 lbs./acre
Sep. 1-Feb. 28	Tall Fescue Centipede Unhulled Common Bermudagrass Fertilizer Limestone	50 lbs./acre 5 lbs./acre 35 lbs./acre 500 lbs./acre 4000 lbs./acre

Slopes (2:1 and steeper) and Waste & Borrow Locations

Jan. 1-Dec. 31	Tall Fescue Unhulled Common Bermudagrass Fertilizer Limestone	75 lbs./acre 35 lbs./acre 500 lbs./acre 4000 lbs./acre
----------------	--	---

Approved Tall Fescue Cultivars

Adventure	Adventure II	Amigo	Anthem
Apache	Apache II	Arid	Austin
Brookstone	Coranzo	Bonanza II	Chapel Hill
Chesapeake	Chieftain	Coronado	Crossfire II
Debutante	Duster	Falcon	Falcon II
Finelawn Petite	Finelawn	Finelawn I	Genesis II
Grande	Guardian	Hawk	Hounddog
Jaguar	Jaguar III	Kentucky 31	Kitty
Monarch	Montauk	Mustang	Olympic
Pacer	Phoenix	Pixie	Pyramid
Rebel	Shenandoah	Rebel II	Renegade
Safari	Tombawik	Triumph	Titan
Wolfpack	Wrangle	Tribe	Vegas

SEEDING AND MULCHING

On cut and fill slopes 2:1 or steeper, add 30* (123kg) Sericea Lespedeza January 1-December 31.

Fertilizer shall be 10-20-20 analysis. Upon written approval of the Engineer, a different analysis of fertilizer may be used provided the 1-2-2 ratio is maintained and the rate of application adjusted to provide the same amount of plant food as a 10-20-20 analysis.

SEEDBED PREPARATION

The Contractor shall cut and satisfactorily dispose of weeds or other unacceptable growth on the areas to be seeded. Uneven and rough areas outside of the graded section, such as crop rows, form contours, ditches, and ditch spoil banks, fence line and hedgerow, soil accumulations, and other minor irregularities which cannot be obliterated by normal seedbed preparation operations, shall be shaped and smoothed as directed by the Engineer to provide for more effective seeding and for ease of subsequent mowing operations.

The soil shall then be scarified or otherwise loosened to a depth of not less than 5 inches except as otherwise provided below or otherwise directed by the Engineer. Clods shall be broken and the top 2 to 3 inches of soil shall be worked into an acceptable seedbed by the use of soil pulverizers, drag scarifiers, harrows, or by other methods approved by the Engineer. All rock and debris 3 inches or larger shall be removed on median, shoulder, and ditch cut or fill slopes which are 3:1 or flatter, prior to the application of seed and fertilizer.

On cut slopes that are 2:1 and steeper, both the depth of preparation and the degree of smoothness of the seedbed may be reduced as permitted by the Engineer, but in all cases the slope surface shall be scarified, grooved, trenched, or punctured so as to provide pockets, ridges, or trenches in which the seeding materials can lodge. Contractor shall be responsible for providing the required seed bed. It may be necessary to seed these sections with a hydro-seed.

On cut slopes that are either 2:1 or steeper, the Engineer may permit the preparation of a partial or complete seedbed during the grading of the slope, if at the time of seeding and mulching operations such preparation is still in a condition acceptable to the Engineer, additional seedbed preparation may be reduced or eliminated.

Seedbed preparation within 2 feet of the edge of any pavement shall be limited to a depth of 2 to 3 inches.

The preparation of seedbeds shall not be done when the soil is frozen, extremely wet, or when the Engineer determines that it is an otherwise unfavorable working condition.

APPLYING AND COVERING LIMESTONE, FERTILIZER, AND SEED

A) GENERAL:

Seasonal limitation for seeding operations; the kinds of grades of fertilizers; the kinds of seed; and the rates of application of limestone, fertilizer, and seed shall be as stated in the special provisions.

Equipment to be used for the application, covering, or compaction of limestone, fertilizer, and seed shall have been approved by the Engineer before being used on the project. Approval may be revoked at any time if equipment is not maintained in satisfactory working condition, or if the equipment operation damages the seed.

Limestone, fertilizer, and seed shall be applied within 24 hours after completion of seedbed preparation unless otherwise permitted by the Engineer, but no limestone or fertilizer shall be distributed and no seed shall be sown when the Engineer determines the weather and soil conditions are unfavorable for such operations.

During the application of fertilizer, adequate precautions shall be taken to prevent damage to traffic, structures, guardrails, traffic control devices, or any other appurtenances. The Contractor shall either provide adequate drainage covering or change methods of application as required to avoid such damage. When such damage occurs the Contractor shall repair it, including any cleaning that may be necessary.

CONSTRUCTION SPECIFICATIONS

MATERIALS

Determine whether the quality and quantity of available topsoil justifies selective handling. Quality topsoil has the following characteristics:

Texture - loam, sandy loam, and silt loam are best; sandy clay loam, silty clay loam, clay loam, and loamy sand are fair. Do not use heavy clay and organic soils such as peat or muck as topsoil.

Organic matter content - (sometimes referred to as "humic matter") should be greater than 1.5% by weight.

Acidity - pH should be greater than 3.6 before liming, and liming is required if it is less than 6.0.

Soluble salts - should be less than 500 ppm.

Sodium - sodium adsorption ratio should be less than 12.

The depth of material meeting the above qualifications should be at least 2 inches. Soil factors such as slope, depth to water table, and layer thickness affect the ease of excavation and spreading of topsoil.

Generally, the upper part of the soil, which is richest in organic matter, is most desirable; however, material excavated from deeper layers may be worth storing if it meets the other criteria listed above.

Organic soils such as mucks and peats do not make good topsoil. They can be identified by their extremely light weight when dry.

STRIPPING

Strip topsoil only from those areas that will be disturbed by excavation, filling, roadbuilding, or compaction by equipment. A 4 to 6-inch stripping depth is common, but depth varies depending on the site. Determine depth of stripping by taking soil cores at several locations within each area to be stripped. Topsoil depth generally varies along a gradient from hilltop to toe of the slope. Put sediment basins, diversions, and other controls into place before stripping.

STOCKPILING

Select stockpile location to avoid slopes and natural drainageways, avoiding traffic routes. On large sites, spreading is easier and more economical when topsoil is stockpiled in small piles located near areas where they will be used. All stockpile areas used shall be stabilized with silt fence and seeded.

Sediment barriers - Use sediment fences or other barriers where necessary to retain sediment.

RIP RAP (6J5)

CONSTRUCTION SPECIFICATIONS

Subgrade Preparation - Prepare the subgrade for riprap and filter to the required lines and grades shown on the plans. Compact any fill required in the subgrade to a density approximating that of the surrounding undisturbed material or overfill depressions with riprap. Remove brush, trees, stumps and other objectionable material. Cut the subgrade sufficiently deep that the finished grade of the riprap will be at the elevation of the surrounding area. Channels should be excavated sufficiently to allow placement of the riprap in a manner such that the finished inside dimensions and grade of the riprap meet design specifications.

Sand and gravel filter blanket - Place the filter blanket immediately after the ground foundation is prepared. In gravel, spread a filter stone in a uniform layer to the specified depth. Where more than one layer of filter material is used, spread the layers with minimal mixing.

Synthetic filter fabric - Place the cloth filter directly on the prepared foundation. Overlap the edges by at least 12 inches, and space anchor pins every 3 ft along the overlap. Bury the upstream end of the cloth a minimum of 12 inches below ground and where necessary, bury the lower end of the cloth or overlap with the next section as required. Take care not to damage the cloth when placing riprap. If damage occurs remove the riprap and repair the steel by adding another layer of filter material with a minimum overlap of 12 inches around the damaged area. If extensive damage is suspected, remove and replace the entire steel.

Where large stones are used or machine placement is difficult, a 4-inch layer of 1/2" gravel or sand may be needed to protect the filter cloth.

Stone Placement - Placement of riprap should follow immediately after placement of the filter. Place riprap so that it forms a dense, well-graded mass of stone with a minimum of voids. The desired distribution of stones throughout the mass may be obtained by selective loading at the quarry and controlled dumping during final placement. Place riprap to its full thickness in one operation. Do not place riprap by dumping through chutes or other methods that cause segregation of stone sizes. Take care not to dislodge the underlying base or filter when placing the stones.

The finished slope should be free of pockets of small stone or clusters of large stones. Hand placing may be necessary to achieve the proper distribution of stone sizes to produce a relatively smooth, uniform surface. The finished grade of the riprap should blend with the surrounding area. No overfall or protrusion of riprap should be apparent.

MAINTENANCE

Inspect channels at regular intervals as well as after major rains, and make repairs promptly. Give special attention to the outlet and inlet sections and other points where concentrated flow enters. Carefully check stability at road crossings and look for indications of piping, scour holes, or bank failures. Make repairs immediately. Maintain all vegetation adjacent to the channel in a healthy, vigorous condition to protect the area from erosion and scour during out-of-bank flow. Control of weed and brush growth may be needed in some locations.

CONSTRUCTION SPECIFICATIONS

MATERIALS

Determine whether the quality and quantity of available topsoil justifies selective handling. Quality topsoil has the following characteristics:

Texture - loam, sandy loam, and silt loam are best; sandy clay loam, silty clay loam, clay loam, and loamy sand are fair. Do not use heavy clay and organic soils such as peat or muck as topsoil.

Organic matter content - (sometimes referred to as "humic matter") should be greater than 1.5% by weight.

Acidity - pH should be greater than 3.6 before liming, and liming is required if it is less than 6.0.

Soluble salts - should be less than 500 ppm.

Sodium - sodium adsorption ratio should be less than 12.

The depth of material meeting the above qualifications should be at least 2 inches. Soil factors such as slope, depth to water table, and layer thickness affect the ease of excavation and spreading of topsoil.

Generally, the upper part of the soil, which is richest in organic matter, is most desirable; however, material excavated from deeper layers may be worth storing if it meets the other criteria listed above.

Organic soils such as mucks and peats do not make good topsoil. They can be identified by their extremely light weight when dry.

STRIPPING

Strip topsoil only from those areas that will be disturbed by excavation, filling, roadbuilding, or compaction by equipment. A 4 to 6-inch stripping depth is common, but depth varies depending on the site. Determine depth of stripping by taking soil cores at several locations within each area to be stripped. Topsoil depth generally varies along a gradient from hilltop to toe of the slope. Put sediment basins, diversions, and other controls into place before stripping.

STOCKPILING

Select stockpile location to avoid slopes and natural drainageways, avoiding traffic routes. On large sites, spreading is easier and more economical when topsoil is stockpiled in small piles located near areas where they will be used. All stockpile areas used shall be stabilized with silt fence and seeded.

Sediment barriers - Use sediment fences or other barriers where necessary to retain sediment.

RIP RAP (6J5)

CONSTRUCTION SPECIFICATIONS

Subgrade Preparation - Prepare the subgrade for riprap and filter to the required lines and grades shown on the plans. Compact any fill required in the subgrade to a density approximating that of the surrounding undisturbed material or overfill depressions with riprap. Remove brush, trees, stumps and other objectionable material. Cut the subgrade sufficiently deep that the finished grade of the riprap will be at the elevation of the surrounding area. Channels should be excavated sufficiently to allow placement of the riprap in a manner such that the finished inside dimensions and grade of the riprap meet design specifications.

Sand and gravel filter blanket - Place the filter blanket immediately after the ground foundation is prepared. In gravel, spread a filter stone in a uniform layer to the specified depth. Where more than one layer of filter material is used, spread the layers with minimal mixing.

Synthetic filter fabric - Place the cloth filter directly on the prepared foundation. Overlap the edges by at least 12 inches, and space anchor pins every 3 ft along the overlap. Bury the upstream end of the cloth a minimum of 12 inches below ground and where necessary, bury the lower end of the cloth or overlap with the next section as required. Take care not to damage the cloth when placing riprap. If damage occurs remove the riprap and repair the steel by adding another layer of filter material with a minimum overlap of 12 inches around the damaged area. If extensive damage is suspected, remove and replace the entire steel.

Where large stones are used or machine placement is difficult, a 4-inch layer of 1/2" gravel or sand may be needed to protect the filter cloth.

Stone Placement - Placement of riprap should follow immediately after placement of the filter. Place riprap so that it forms a dense, well-graded mass of stone with a minimum of voids. The desired distribution of stones throughout the mass may be obtained by selective loading at the quarry and controlled dumping during final placement. Place riprap to its full thickness in one operation. Do not place riprap by dumping through chutes or other methods that cause segregation of stone sizes. Take care not to dislodge the underlying base or filter when placing the stones.

The finished slope should be free of pockets of small stone or clusters of large stones. Hand placing may be necessary to achieve the proper distribution of stone sizes to produce a relatively smooth, uniform surface. The finished grade of the riprap should blend with the surrounding area. No overfall or protrusion of riprap should be apparent.

MAINTENANCE

Inspect channels at regular intervals as well as after major rains, and make repairs promptly. Give special attention to the outlet and inlet sections and other points where concentrated flow enters. Carefully check stability at road crossings and look for indications of piping, scour holes, or bank failures. Make repairs immediately. Maintain all vegetation adjacent to the channel in a healthy, vigorous condition to protect the area from erosion and scour during out-of-bank flow. Control of weed and brush growth may be needed in some locations.

CONSTRUCTION SPECIFICATIONS

MATERIALS

Determine whether the quality and quantity of available topsoil justifies selective handling. Quality topsoil has the following characteristics:

Texture - loam, sandy loam, and silt loam are best; sandy clay loam, silty clay loam, clay loam, and loamy sand are fair. Do not use heavy clay and organic soils such as peat or muck as topsoil.

Organic matter content - (sometimes referred to as "humic matter") should be greater than 1.5% by weight.

Acidity - pH should be greater than 3.6 before liming, and liming is required if it is less than 6.0.

Soluble salts - should be less than 500 ppm.

Sodium - sodium adsorption ratio should be less than 12.

The depth of material meeting the above qualifications should be at least 2 inches. Soil factors such as slope, depth to water table, and layer thickness affect the ease of excavation and spreading of topsoil.

Generally, the upper part of the soil, which is richest in organic matter, is most desirable; however, material excavated from deeper layers may be worth storing if it meets the other criteria listed above.

Organic soils such as mucks and peats do not make good topsoil. They can be identified by their extremely light weight when dry.

STRIPPING

Strip topsoil only from those areas that will be disturbed by excavation, filling, roadbuilding, or compaction by equipment. A 4 to 6-inch stripping depth is common, but depth varies depending on the site. Determine depth of stripping by taking soil cores at several locations within each area to be stripped. Topsoil depth generally varies along a gradient from hilltop to toe of the slope. Put sediment basins, diversions, and other controls into place before stripping.

K:\DUR_Roadway\013936008 - Midway_Business_Park\Plan\Erosion_Contra\013936008_psh_ero_DTL.dgn

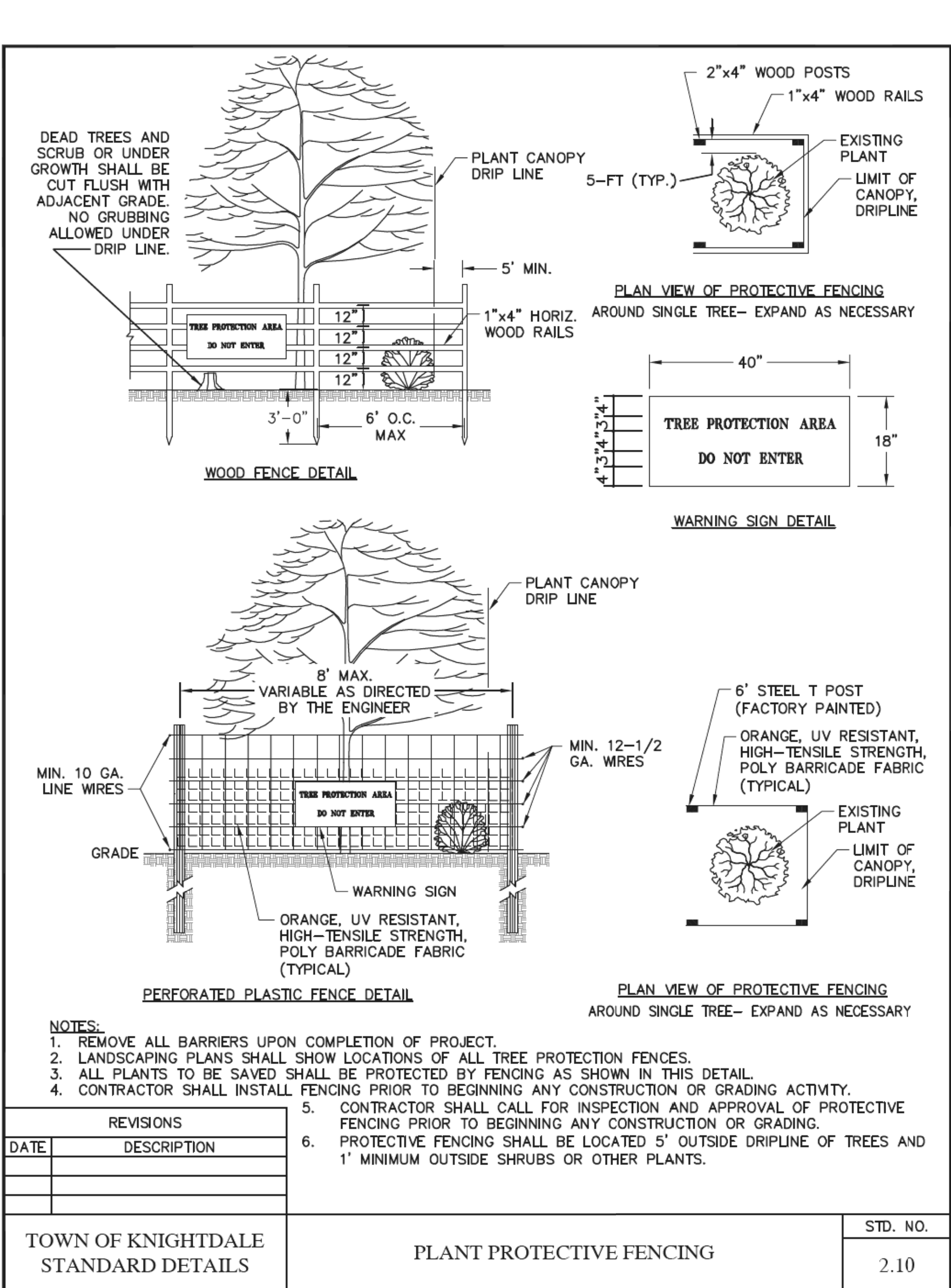
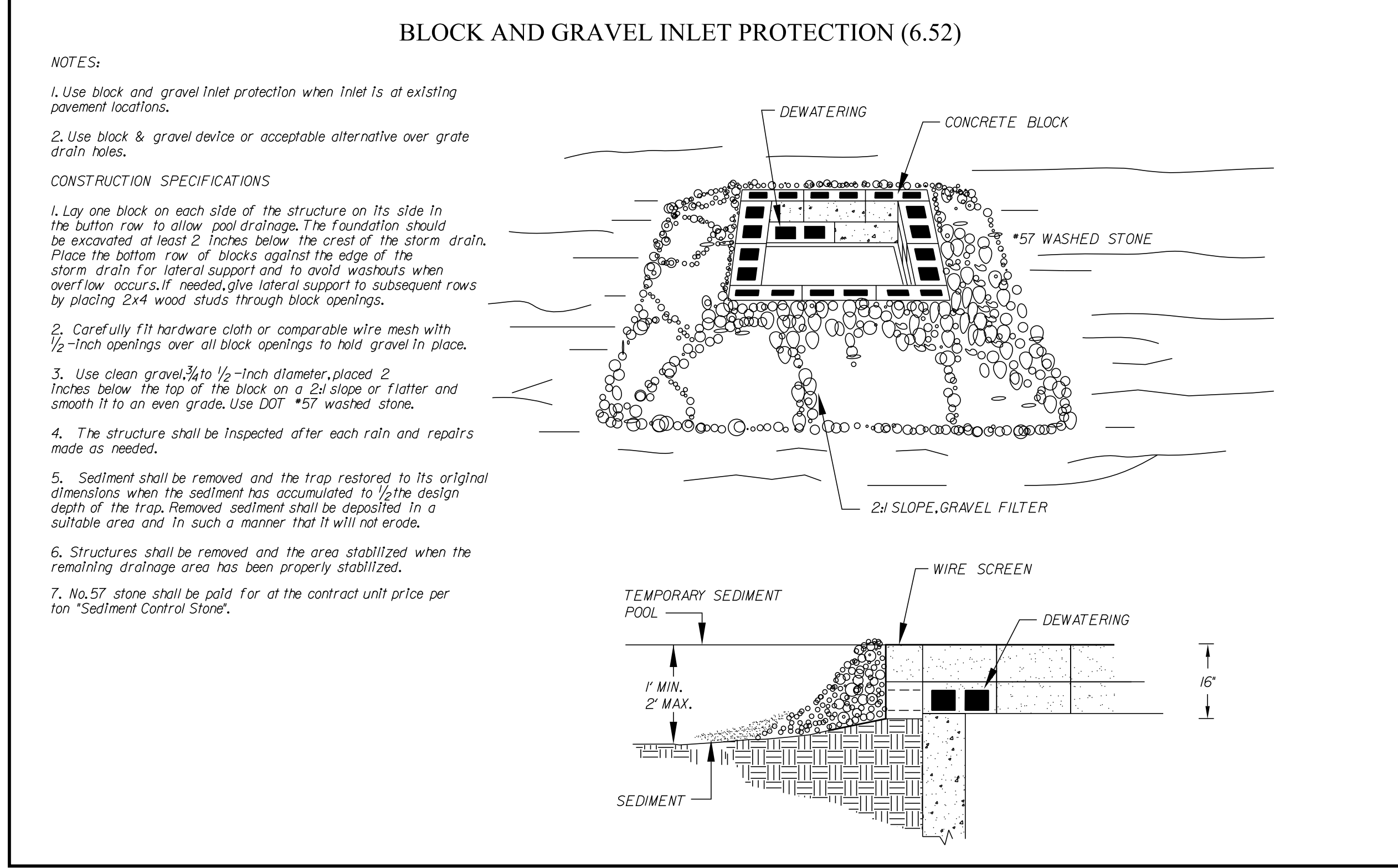
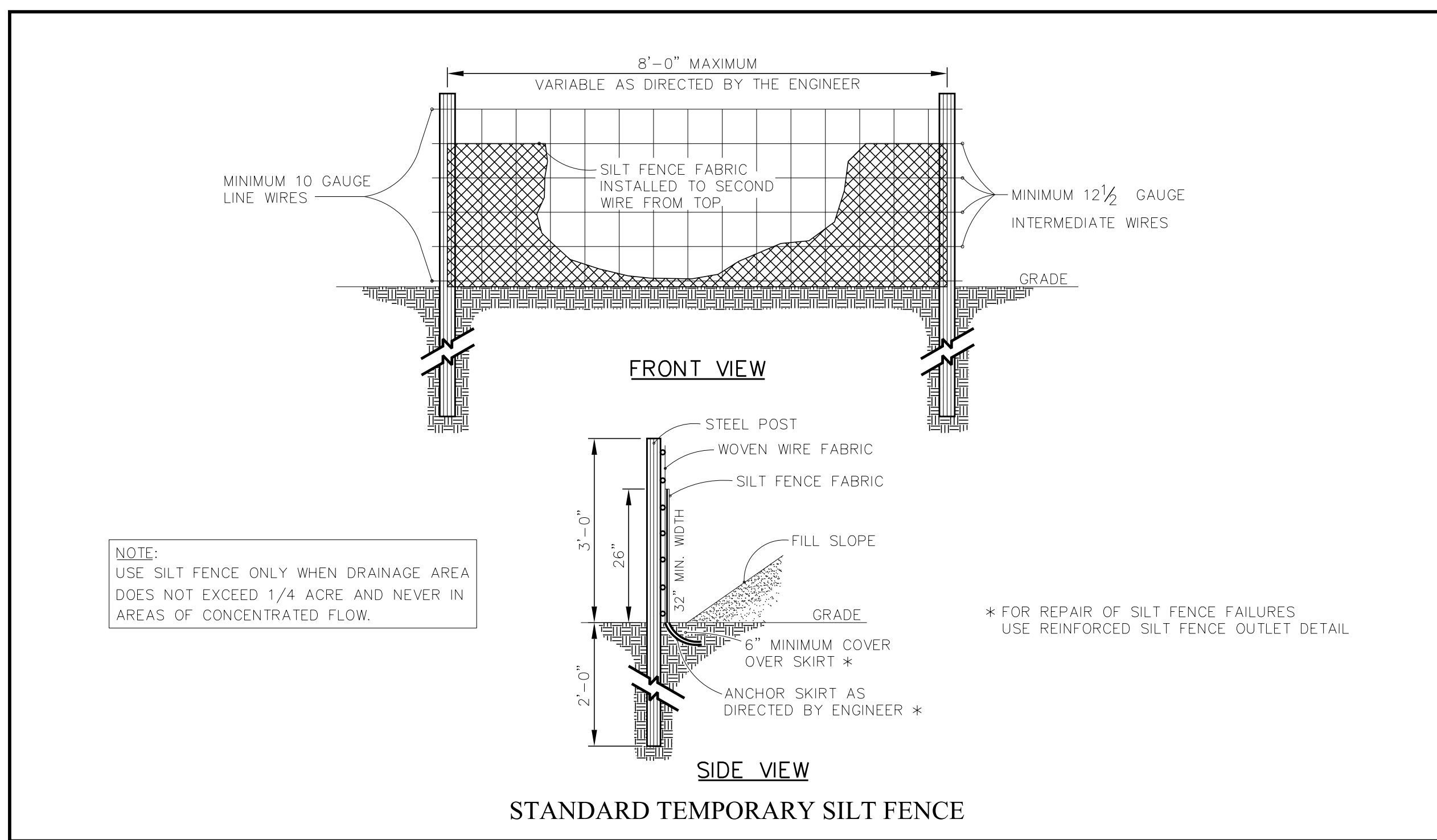

4. Town Certification. This design has been reviewed by the Engineer for the Town of Knightdale, and to the best of my knowledge and belief, it conforms to the requirements established in the Standard Specifications of the Town of Knightdale.
By: _____ Date: _____
Town Engineer
These plans are approved by the Town of Knightdale and serve as construction plans for this project.
By: _____ Date: _____
Administrator

MERRITT HINTON OAKS BLVD OFFSITE IMPROVEMENTS

EROSION CONTROL DETAILS

KIMLEY HORN

© 2021
300 MORRIS STREET, SUITE 200, DURHAM, NC, 27701
PHONE: 919-682-3583
WWW.KIMLEY-HORN.COM
NC LICENSE # F-0102

NORTH CAROLINA PROFESSIONAL SEAL
TYLER D. WILSON
4/15/2022

KHA PROJECT 013936008
DATE 4/4/2022
SCALE 1"=40'
DESIGNED BY: TDW
DRAWN BY: LCK
CHECKED BY: TDW

MERRITT HINTON OAKS BLVD OFFSITE IMPROVEMENTS

NORTH CAROLINA

KNIGHTDALE

SHEET NUMBER R5.02

K:\DUP_Roadway\013936008 - Midway Business Park\Plan\Cross-Sections\013936008_xpl.Ldgn
4/4/2022

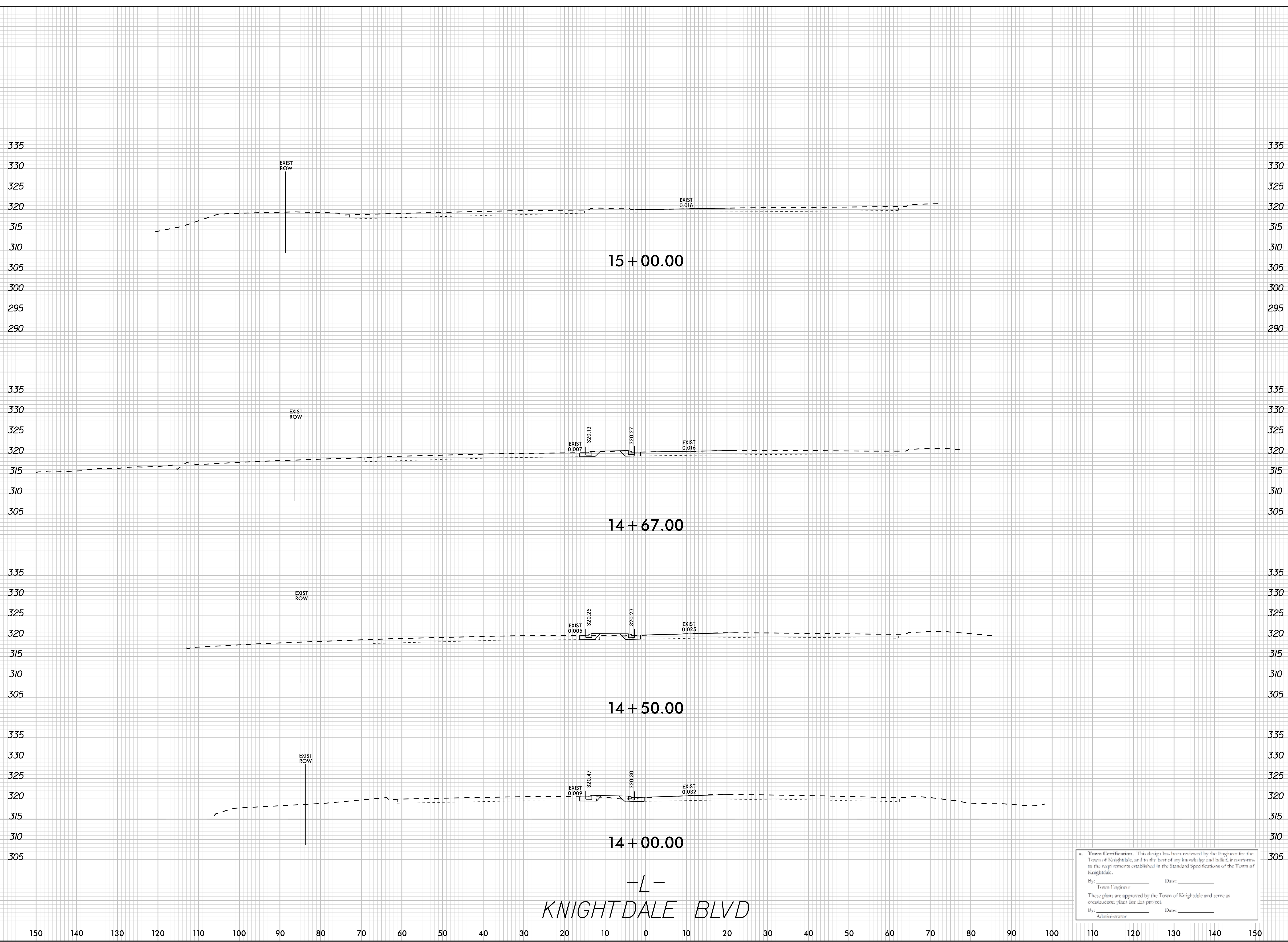

1. Town Certification. This design has been reviewed by the Engineer for the Town of Knightdale, and to the best of my knowledge and belief, it conforms to the requirements established in the Standard Specifications of the Town of Knightdale.

By: _____ Date: _____
Town Engineer

These plans are approved by the Town of Knightdale and serve as construction plans for this project.

By: _____ Date: _____
Administrator

KHA PROJECT 013936008		DATE 4/4/2022	SCALE 1" = 10'	DESIGNED BY TOW	LCK	CHECKED BY TOW
		<p>Kimley»Horn</p> <p>© 2021 300 MORRIS STREET, SUITE 200, DURHAM, NC, 27701 PHONE: 919-682-3583 WWW.KIMLEY-HORN.COM NC LICENSE #: F-0102</p>				
<p>MERRITT HINTON OAKS BLVD OFFSITE IMPROVEMENTS</p>		<p>ROADWAY CROSS-SECTIONS</p>				
SHEET NUMBER R6.02		<p>KNIGHTDALE NORTH CAROLINA</p>				
REVISIONS						BY
						DATE

K:\DUR_Roadway\013936008 - Midway Business Park\Plan\Cross-Sections\013936008_xp_L1.dgn
4/4/2022

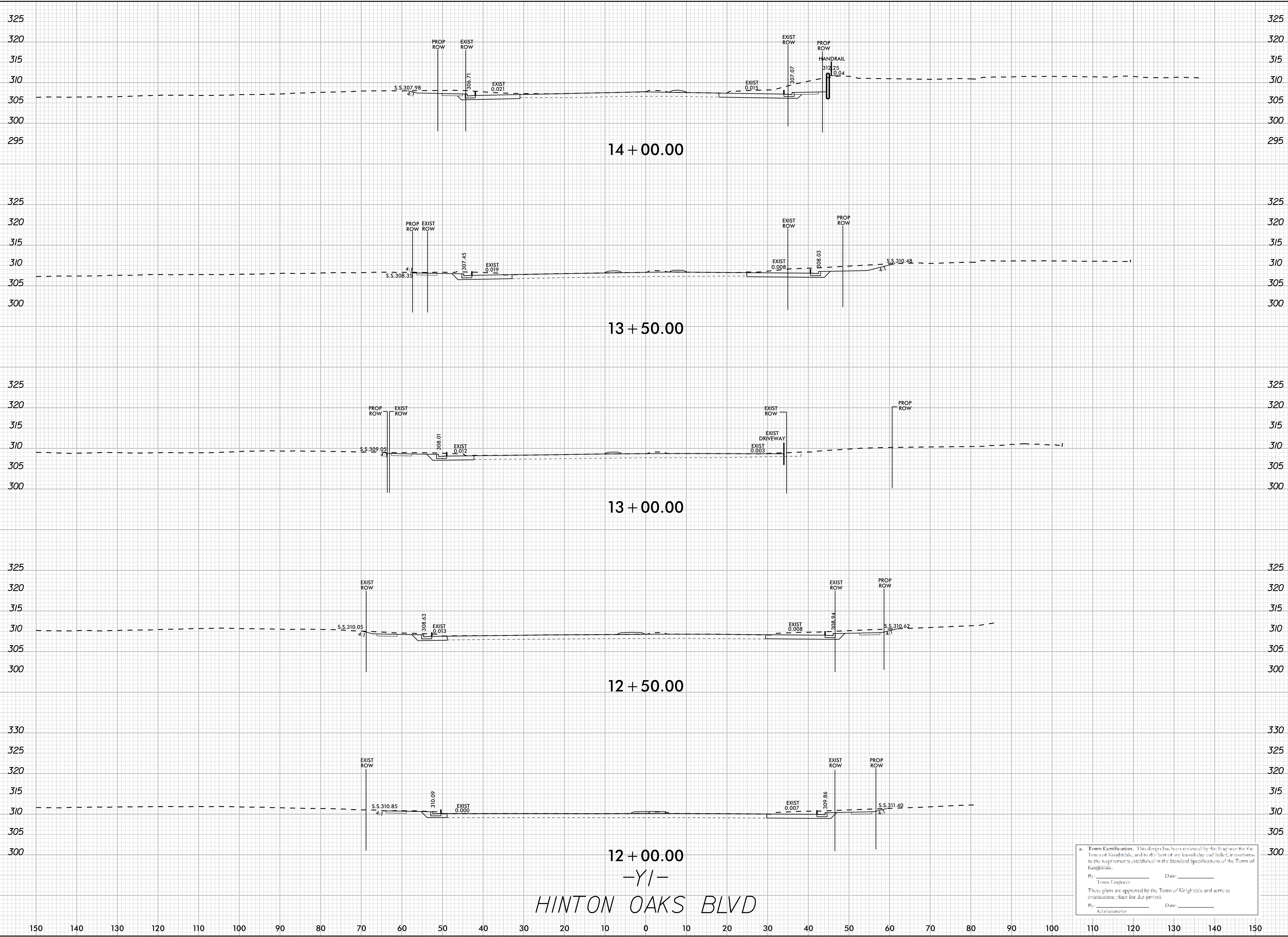

* Town Certification: This design has been reviewed by the Engineer for the Town of Knightdale, and to the best of my knowledge and belief, it conforms to the requirements established in the Standard Specifications of the Town of Knightdale.
 By: _____ Date: _____
 Town Engineer
 These plans are approved by the Town of Knightdale and serve as construction plans for this project.
 By: _____ Date: _____
 Administrator

No.	REVISIONS	DATE	BY

Kimley»Horn

© 2021
 300 MORRIS STREET, SUITE 200, DURHAM, NC, 27701
 PHONE: 919-682-3583
 WWW.KIMLEY-HORN.COM
 NC LICENSE #: F-0102

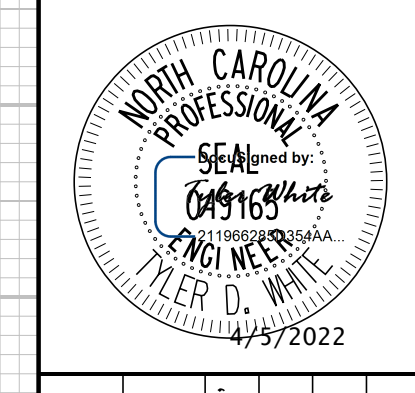

KHA PROJECT	013936008
DATE	4/4/2022
SCALE	1" = 10'
DESIGNED BY:	TDW
DRAWN BY:	LCK
CHECKED BY:	TDW

ROADWAY CROSS-SECTIONS

MERRITT HINTON OAKS BLVD OFFSITE IMPROVEMENTS

NORTH CAROLINA

K:\DUP_Roadway\013936008 - Midway Business Park\PlanCross-Sections\013936008_xpl_1.dgn
4/4/2022

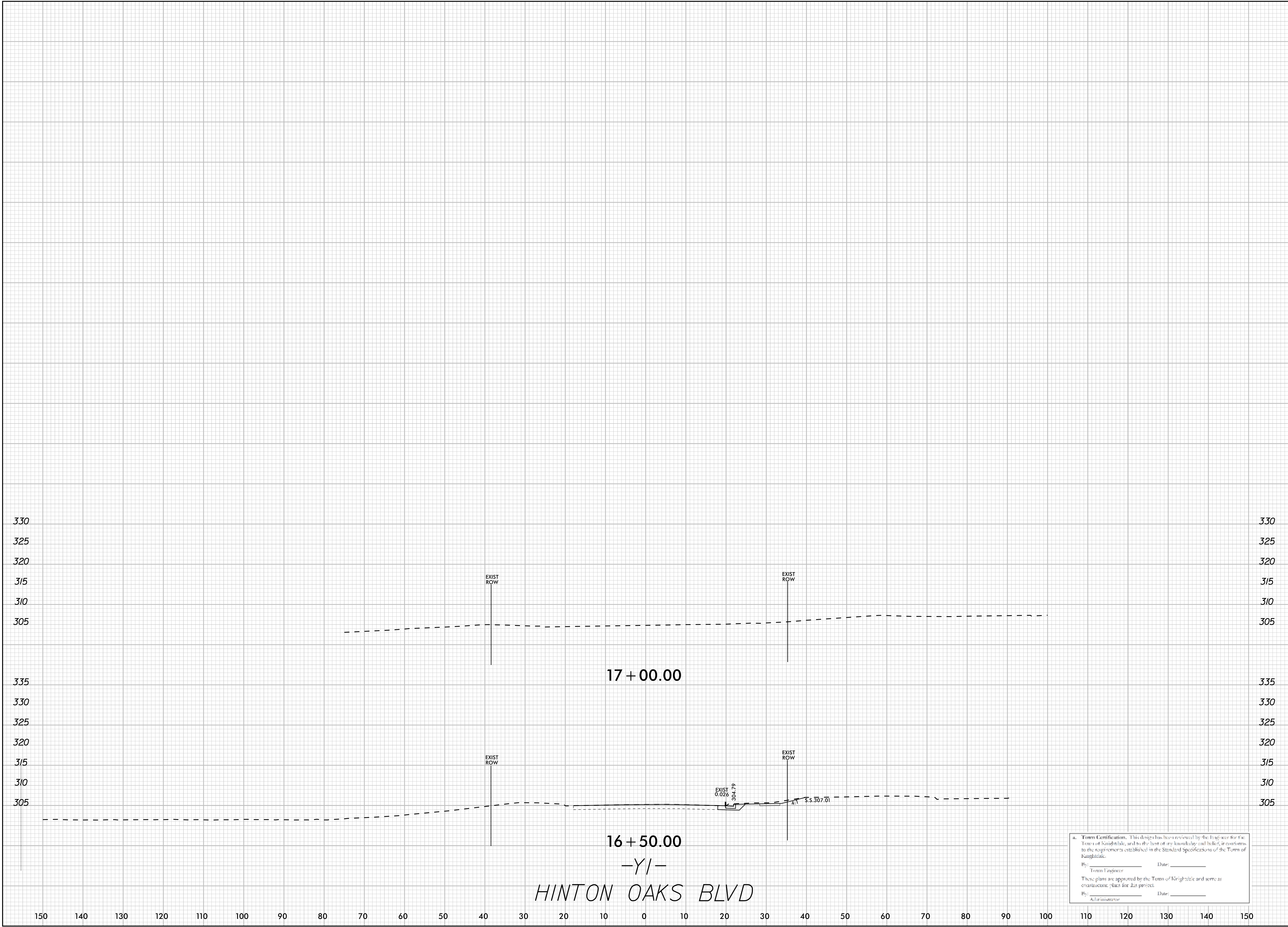

a. **Town Certification.** This design has been reviewed by the Engineer for the Town of Knightdale, and to the best of my knowledge and belief, it conforms to the requirements established in the Standard Specifications of the Town of Knightdale.

By: _____ Date: _____
Town Engineer

These plans are approved by the Town of Knightdale and serve as construction plans for this project.

By: _____ Date: _____
Administrator

No.	REVISIONS	DATE	BY

Kimley»Horn

© 2021
300 MORRIS STREET, SUITE 200, DURHAM, NC, 27701
PHONE: 919-682-3583
WWW.KIMLEY-HORN.COM
NC LICENSE #: F-0102

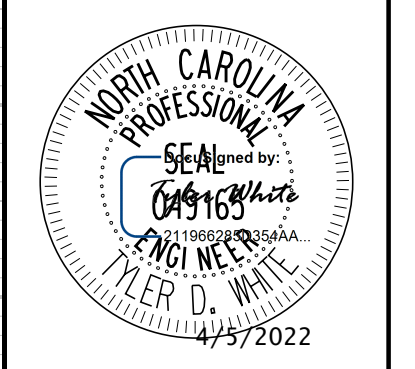

KHA PROJECT	013936008
DATE	4/4/2022
SCALE	1"=10'
DESIGNED BY:	TDW
DRAWN BY:	LCK
CHECKED BY:	TDW

**ROADWAY
CROSS-SECTIONS**

**MERRITT HINTON OAKS
BLVD OFFSITE
IMPROVEMENTS**

NORTH CAROLINA
KNIGHTDALE

SHEET NUMBER
R6.06

